











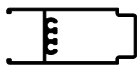

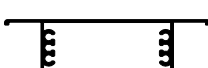
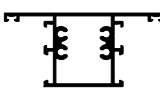
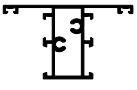

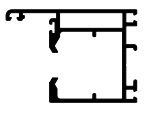

**50 FLEX**  
**sistema per verande a libro**

CODICE PESO Kg/m	SEZIONE	DESCRIZIONE
<b>E 41000</b> 0.135		ASTINA
<b>E 41304</b> 1.670		FASCIA 150mm
<b>E 41305</b> 0.830		ZOCCOLO RIPORTATO VETRO INF.
<b>E 41306</b> 1.150		ZOCCOLO RIPORTATO
<b>E 41310</b> 0.925		FASCIA VETRO INF. 63 mm
<b>E 41311</b> 1.310		FASCIA VETRO INF. 113 mm
<b>E 41312</b> 1.230		FASCIA 90 mm
<b>E 41319</b> 0.977		FASCIA 71.5 mm
<b>E 41606</b> 0.318		RIDUTTORE 10 mm
<b>E 41621</b> 1.440		TELAIO GUIDA

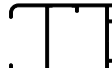
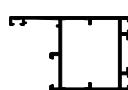
CODICE PESO Kg/m	SEZIONE	DESCRIZIONE
<b>E 41622</b> 0.270		GUIDA RIPORTATA
<b>E 41623</b> 0.510		RIPORTO TELAIO
<b>E 41624</b> 0.308		RIPORTO ZOCCOLO
<b>E 41625</b> 0.490		GUIDA INCASSO
<b>E 41626</b> 0.273		BATTUTA RIPORTATA
<b>E 41627</b> 0.980		ANTA VETRO INF.
<b>E 41628</b> 0.982		ANTA
<b>E 41639</b> 0.480		RIPORTO ANTE PARI
<b>E 51609</b> 0.527		COMPENSAT.
<b>E 10013</b> 0.348		OVALINA

CODICE PESO Kg/m	SEZIONE
<b>E 41701</b> 0.265	
<b>E 41703</b> 0.272	
<b>E 41704</b> 0.313	
<b>E 41706</b> 0.273	
<b>E 41707</b> 0.324	
<b>E 41708</b> 0.285	
<b>E 41710</b> 0.301	
<b>E 41711</b> 0.288	
<b>E 41714</b> 0.178	
<b>E 41717</b> 0.320	
<b>E 41718</b> 0.267	
<b>E 41722</b> 0.201	

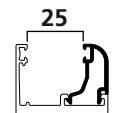
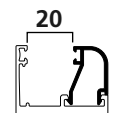
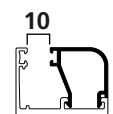
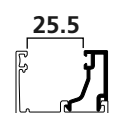
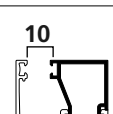
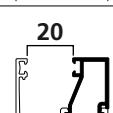
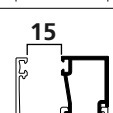
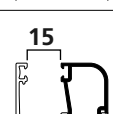
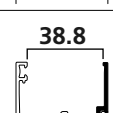
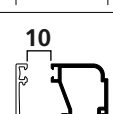
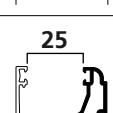
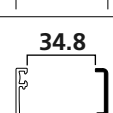













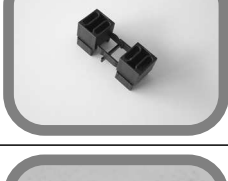
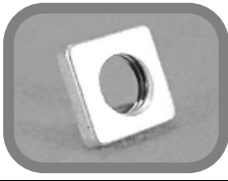
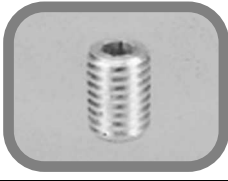

<b>AN 01</b>	angolo pressofuso universale	
<b>FR 01</b> <b>FR 03</b>	fresa per fasce-zoccoli E41302-303-304-306-312-319-602-603 fresa per fasce vetro ad infilare E41305-310-311	
<b>SQ 01</b> <b>SQ 02</b>	squadretta a pulsante 35.7 x 13.7 mm filettata squadretta a pulsante 35.7 x 13.7 mm con dado	
<b>SQ 03</b>	squadretta allineamento a serraggio meccanico mod. Fuji	
<b>SQ 04</b>	squadretta allineamento nylon	
<b>TP 06</b>	tappo paratempesta	
<b>TP 12</b>	giunto fasce E41305-310-311	
<b>1011</b> <b>1012</b> <b>1013</b> <b>1014</b>	basetta regolo regolo mobile L= 15 mm regolo mobile L= 30 mm tappo chiudi foro	 
<b>1083</b>	sella per ovalina 50 x 10 mm - cava da 25 mm	
<b>PU 01</b> <b>PU 02</b>	punzonatrice pneumatica punzonatrice pneumatica	

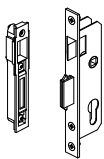
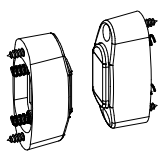
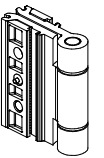
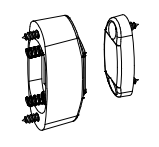
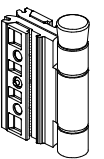
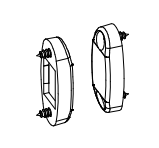
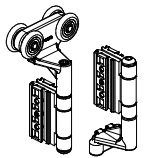
FIGURA	CODICE ETA PEREGO	PZ. CONF.	DESCRIZIONE	FIGURA	CODICE ETA PEREGO	PZ. CONF.	DESCRIZIONE
	<b>VF02</b> EPC150	1	Serratura con borchia.		<b>VF13</b> EPC219	1	Ferma-anta magnetico da 58 mm
	<b>VF03</b> EPM248	2	Cerniera normale.		<b>VF14</b> EPC220	1	Ferma-anta magnetico da 38 mm
	<b>VF04</b> EPM249	2	Cerniera con perno sfilabile.		<b>VF15</b> EPC221	1	Ferma-anta magnetico da 20 mm
	<b>VF05</b> EPM250	1	Coppia carrello e pattino di scorrimento con cerniere. Portata max 160 kg		<b>VF16</b> EPC239	1	Catenacciolo con puntali e guida puntali.
	<b>VF06</b> EPC094	10	Maniglia con perno per serratura (da utilizzare con VF02 o VF19)		<b>VF17</b> EPC 1285	20	Puntali
	<b>VF07</b> EPC236	1	Kit spessori e guida puntali.		<b>VF18</b> EPC135	1	Mezzo cilindro 35 mm
	<b>VF08</b> EPC027	1	Cilindro a doppia chiave da 52mm.		<b>VF19</b> EPC202	10	Meccanismo di chiusura reversibile in zama (esclusa maniglia)
	<b>VF09</b> EPC133	10	Perno per doppia maniglia (VF06).		<b>VF20</b> EPC244	1	Maniglia per VF19-VF02
	<b>VF10</b> EPM254	1	Coppia carrello e pattino di scorrimento destri con cerniere, per n° ante pari Portata max 80 kg		<b>VF21</b> EPC261	1	Maniglia per VF19-VF02
	<b>VF11</b> EPM255	1	Coppia carrello e pattino di scorrimento sinistri con cerniere, per n° ante pari Portata max 80 kg				
	<b>VF12</b> EPC230	10	Maniglia per catenacciolo.		<b>SQ28</b> EPF367	4	Squadretta pressofusa da 36,4X14,4 mm con aggancio interno Nota: da utilizzare per angoli con passaggio astina di comando

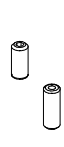
**GU02**  
BATTUTA TELAIO

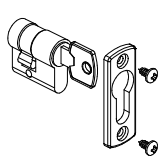
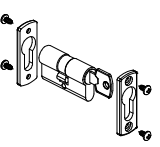
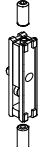
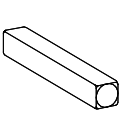

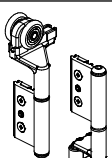
ELAPRENE  
BASE RIGIDA

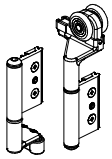
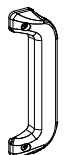
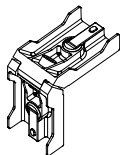
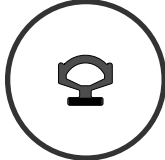
**GU04**  
BATTUTA TELAIO



EPDM  
ESPANSO

**GU05**  
BATTUTA TELAIO

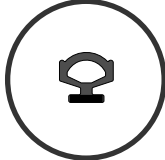

PVC  
BASE RIGIDA

**GU06**  
VETRO ESTERNO  
SPESSORE 3 mm.



EPDM

**GU15**  
BATTUTA TELAIO



EPDM

**GU21**  
BATTUTA



EPDM

**GU22**

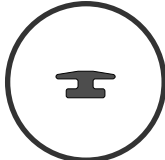

ELAPRENE  
BASE RIGIDA

**SL 7**  
SPAZZOLINO  
4.8 x 7.5 mm



**SP 08**  
SPAZZOLINO  
5.5 x 12 mm



**D1**  
VETRO INTERNO  
SPESSORE 3 mm.



PLASTOMERO

**D4**  
VETRO INTERNO  
SPESSORE 4 mm.



PLASTOMERO

**D6**  
VETRO INTERNO  
SPESSORE 5 mm.



PLASTOMERO

**D7**  
VETRO INTERNO  
SPESSORE 6 mm.



PLASTOMERO

**D8M**  
VETRO INTERNO  
SPESSORE 7 mm.



EPDM

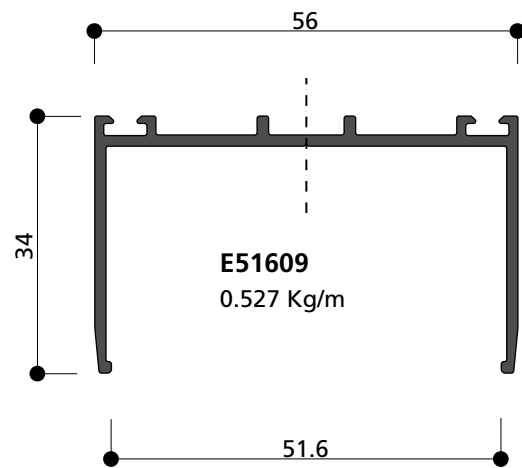
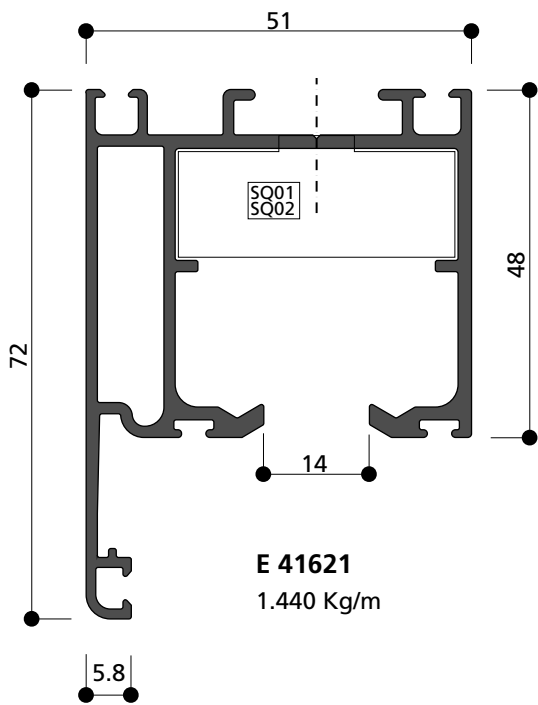

**E 41622**  
 0.270 Kg/m

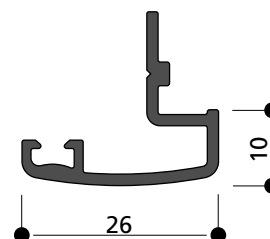
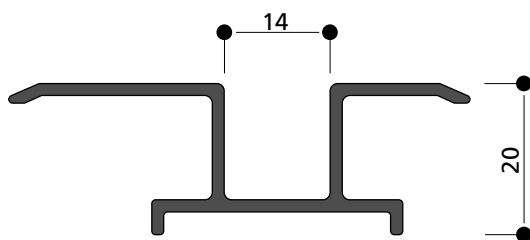
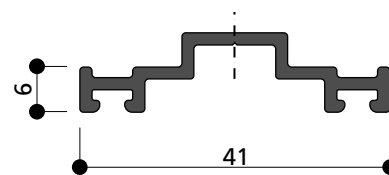
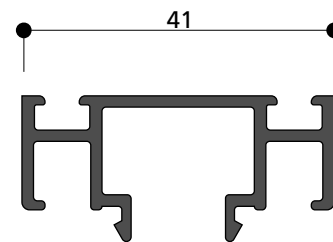
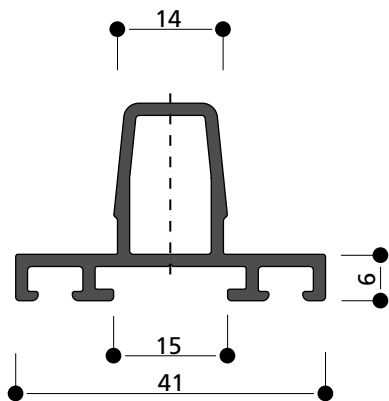

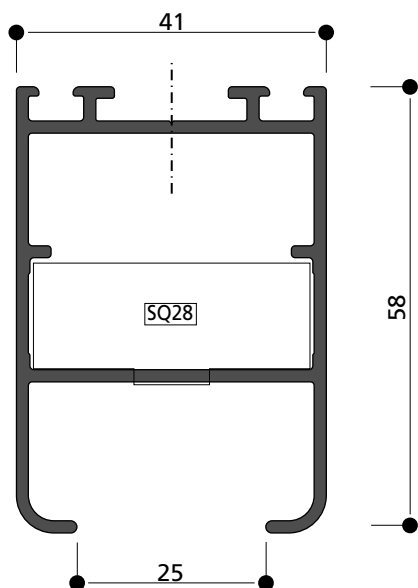

**E 41627**  
 0.980 Kg/m

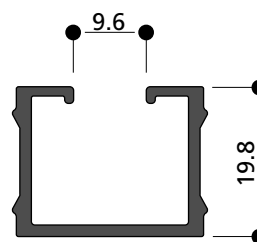

**E41606**  
 0.318 Kg/m



**E41000**  
 0.135 Kg/m

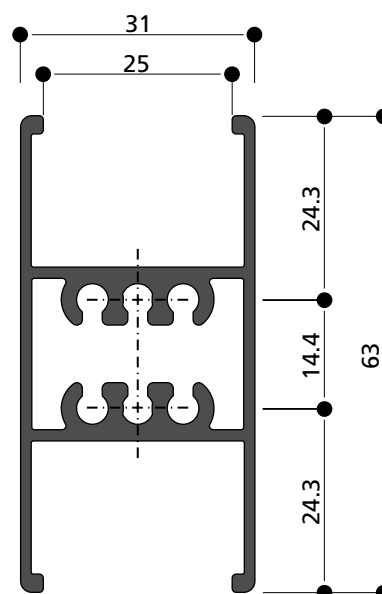

**E41310**  
 0.925 Kg/m

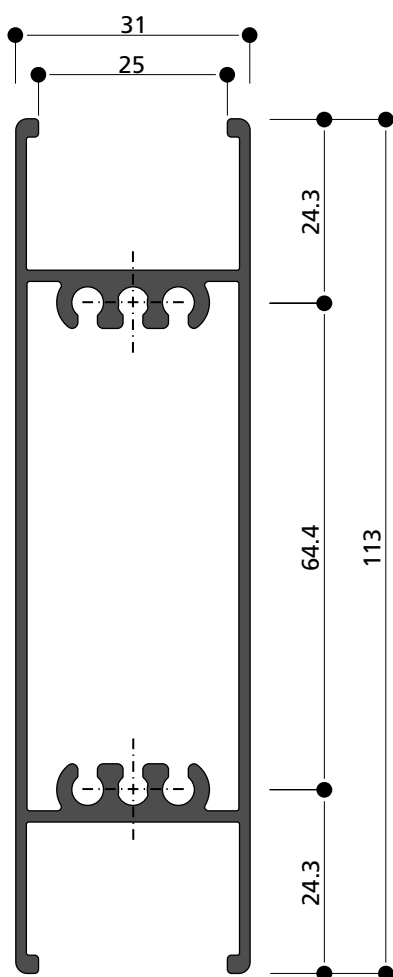

**E41311**  
 1.310 Kg/m

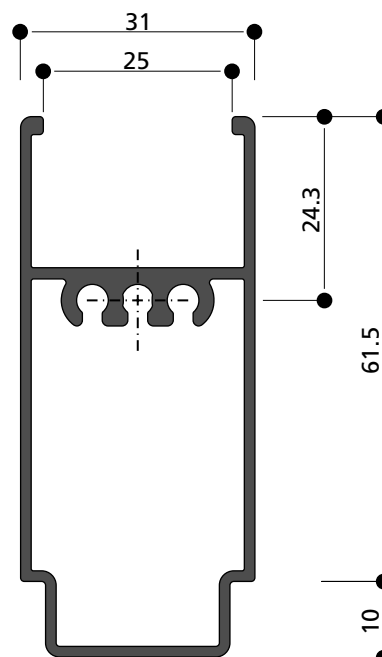

**E41305**  
 0.830 Kg/m

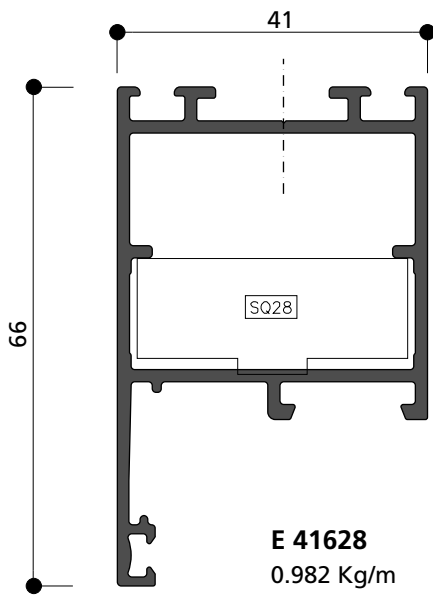

**E 41628**  
0.982 Kg/m

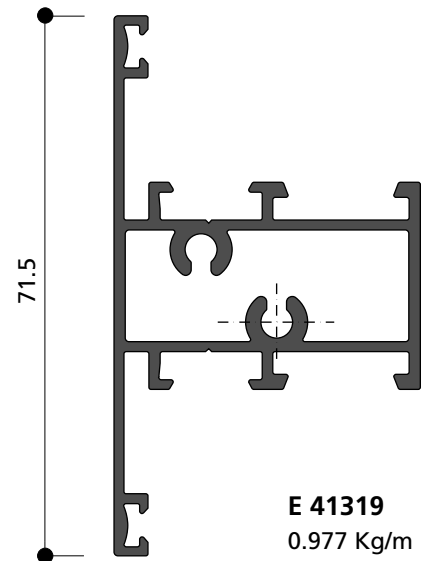

**E 41319**  
0.977 Kg/m

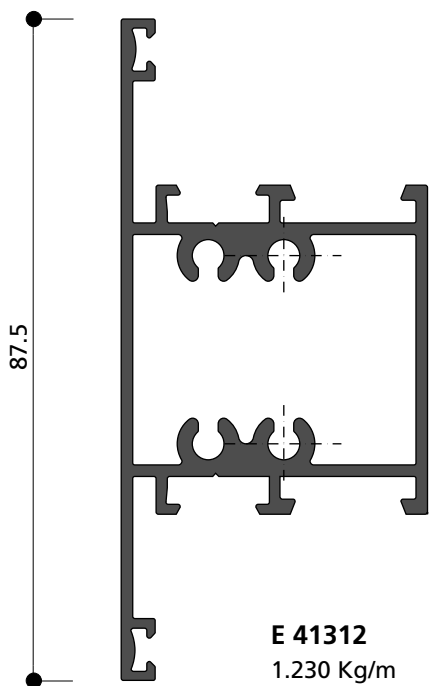

**E 41312**  
1.230 Kg/m

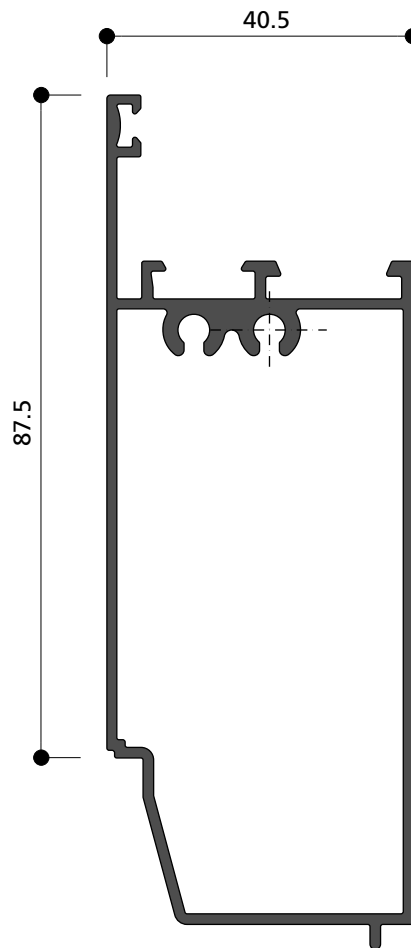

**E 41306**  
1.150 Kg/m

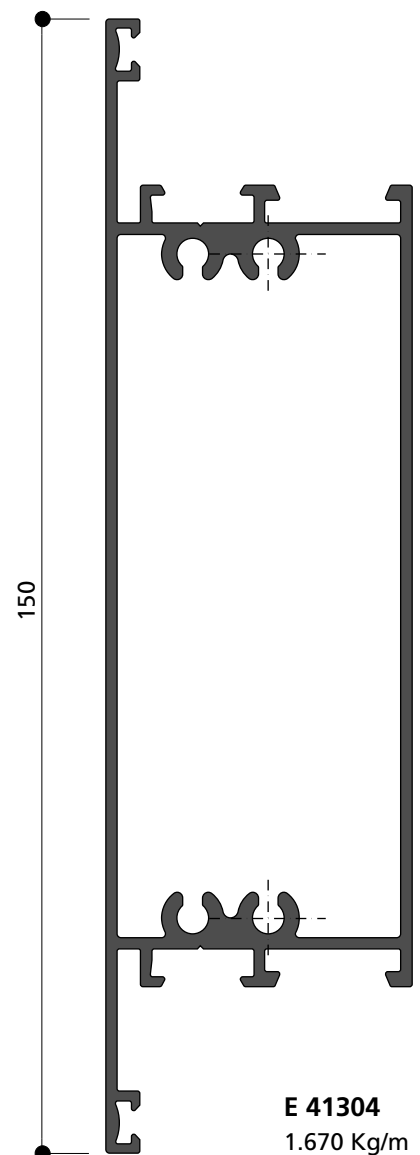

**E 41304**  
1.670 Kg/m



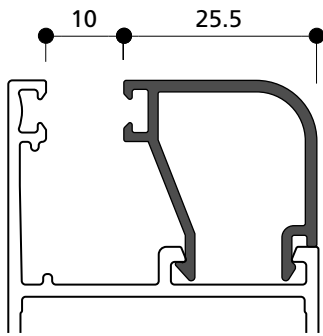

**E 41704**  
0.313 Kg/m

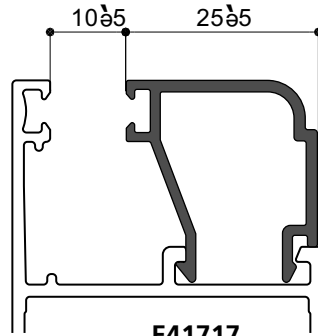

**E41717**  
0.320 Kg/m

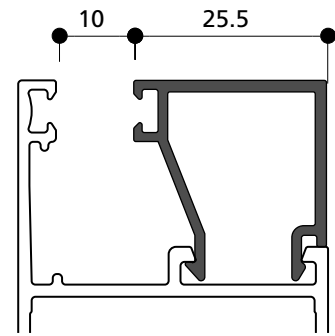

**E 41707**  
0.324 Kg/m

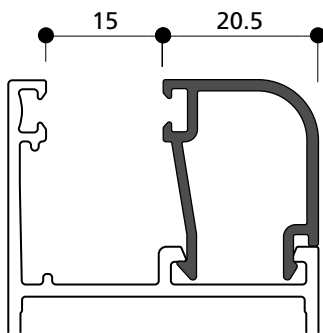

**E 41711**  
0.288 Kg/m

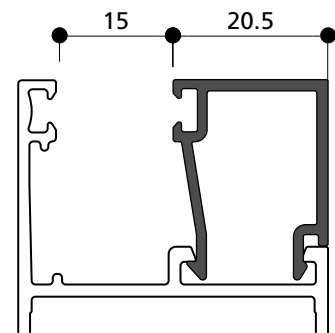

**E 41710**  
0.301 Kg/m

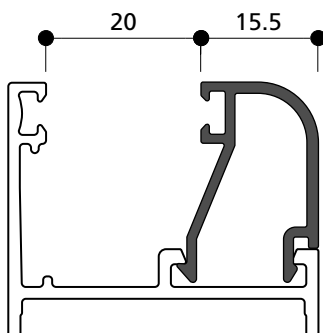

**E 41703**  
0.272 Kg/m

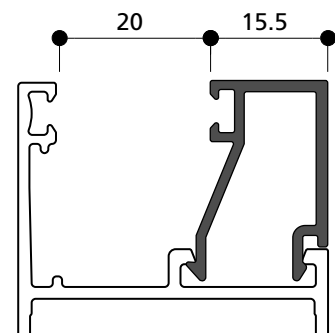

**E 41708**  
0.285 Kg/m

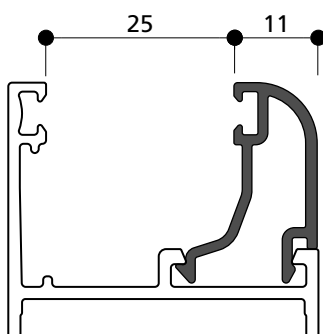

**E 41701**  
0.265 Kg/m

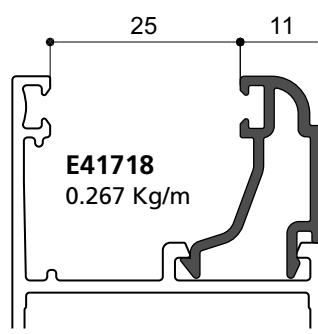

**E41718**  
0.267 Kg/m

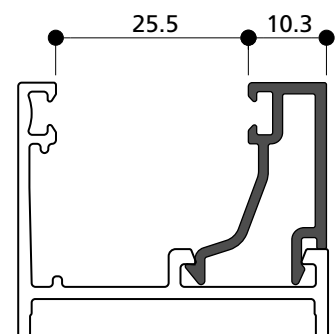

**E 41706**  
0.273 Kg/m

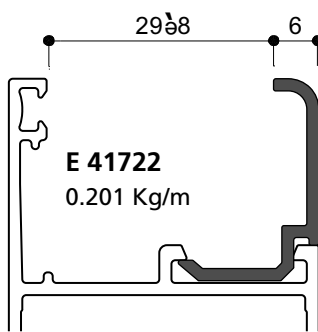

**E 41722**  
0.201 Kg/m

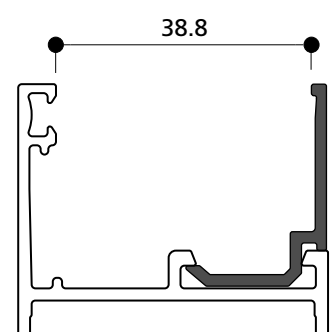

**E 41714**  
0.178 Kg/m

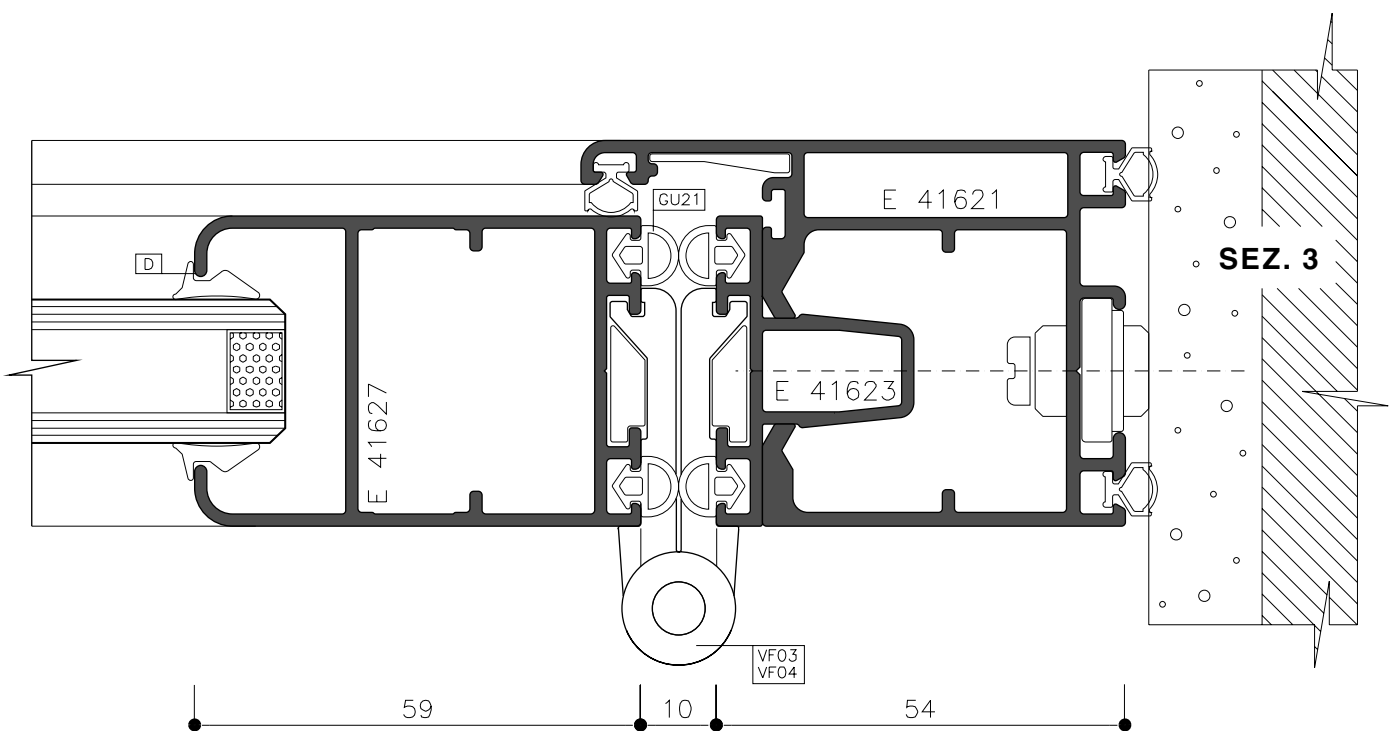
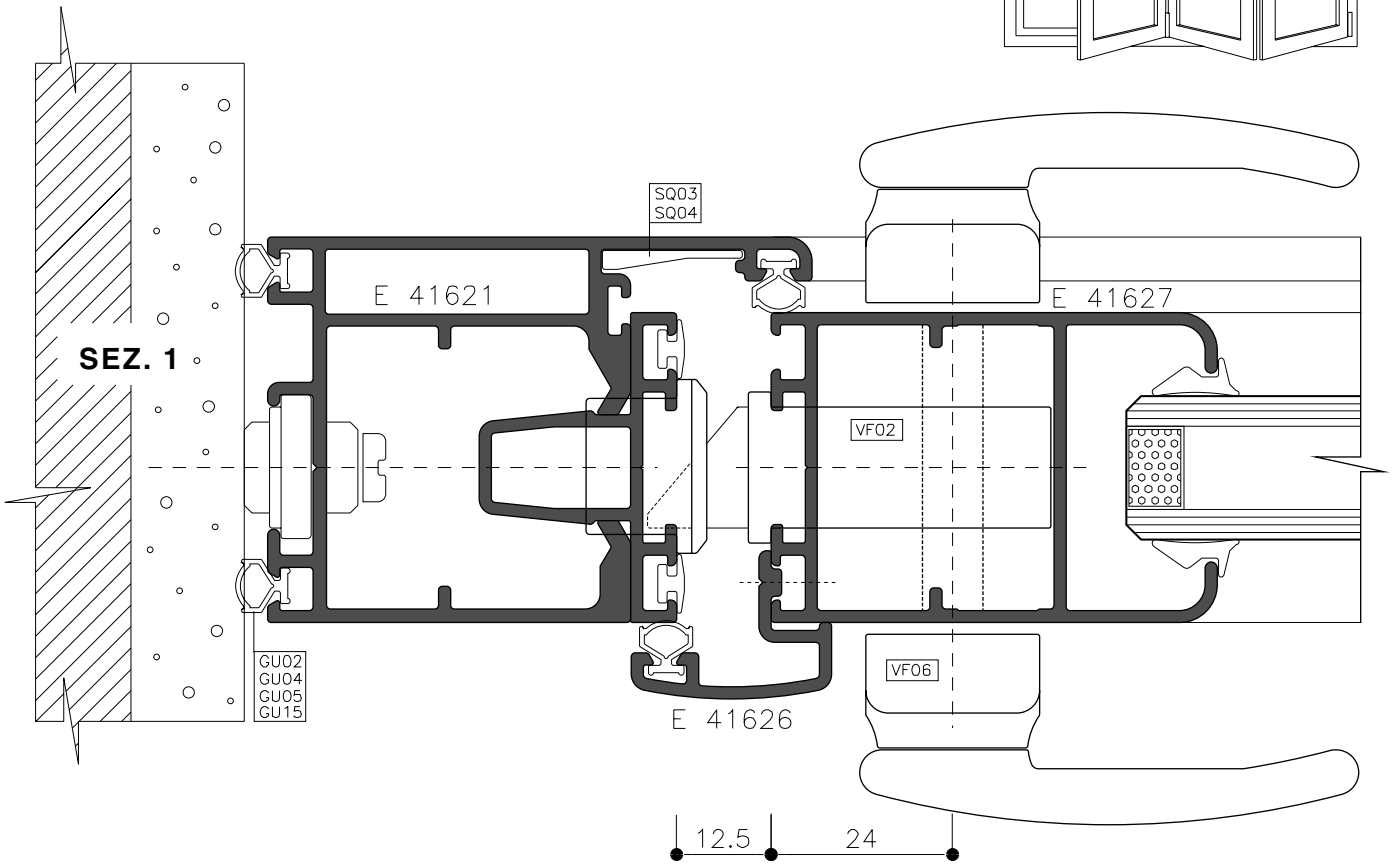
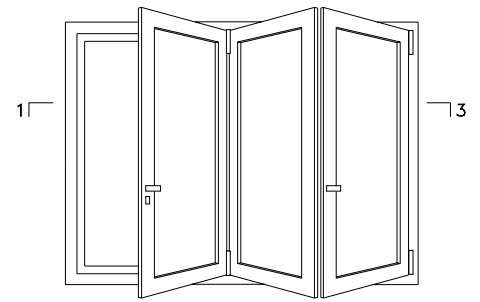

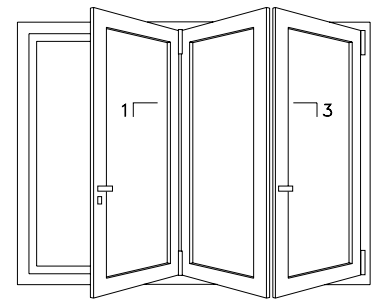

SEZ. 1

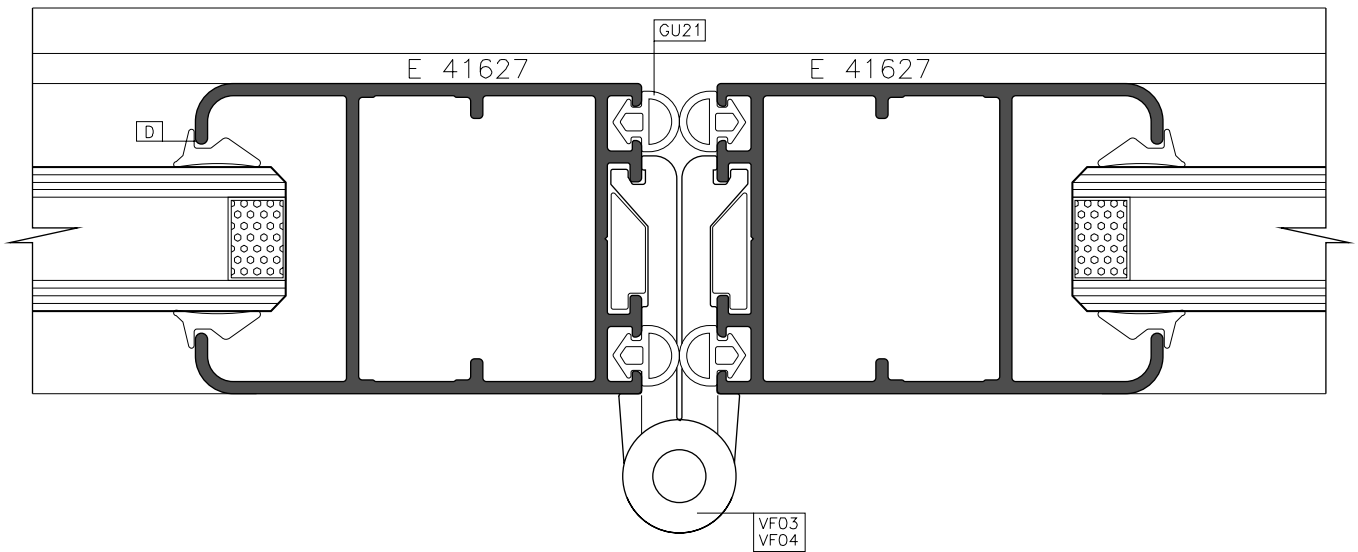

SEZ. 3

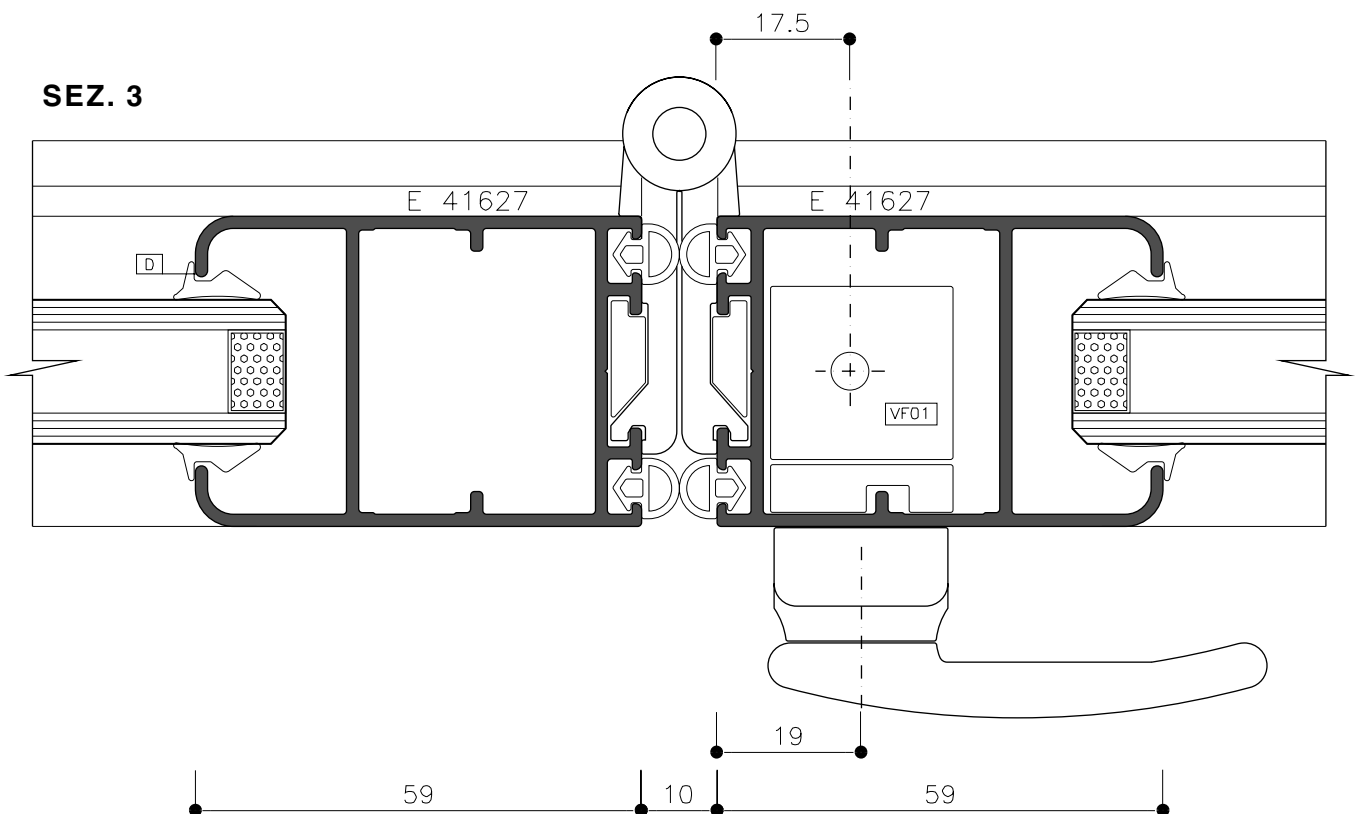

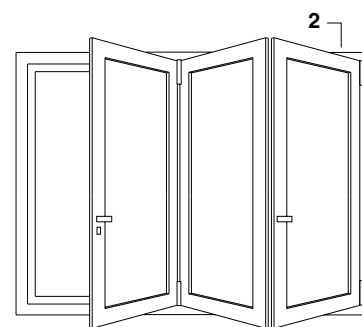
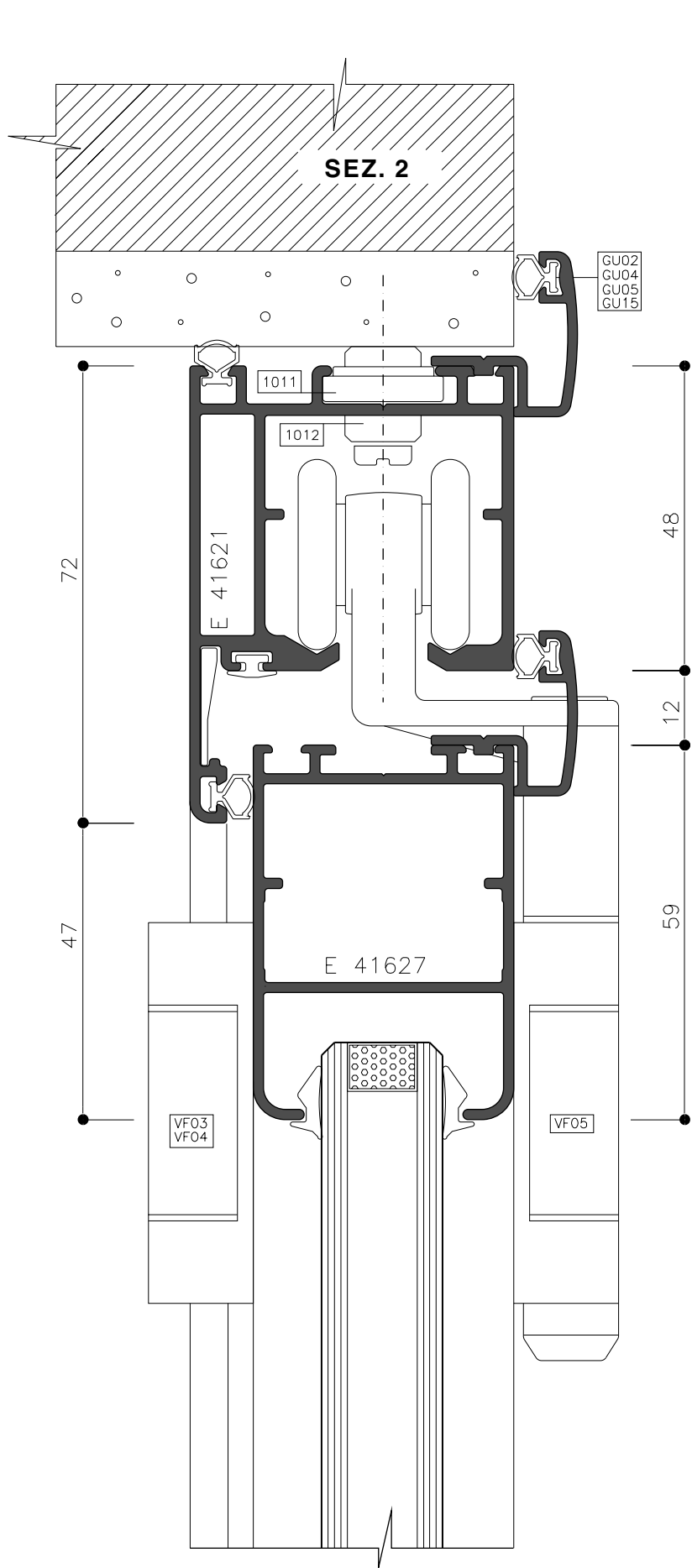

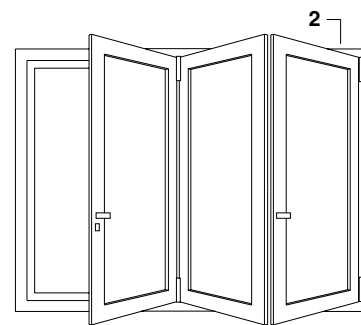
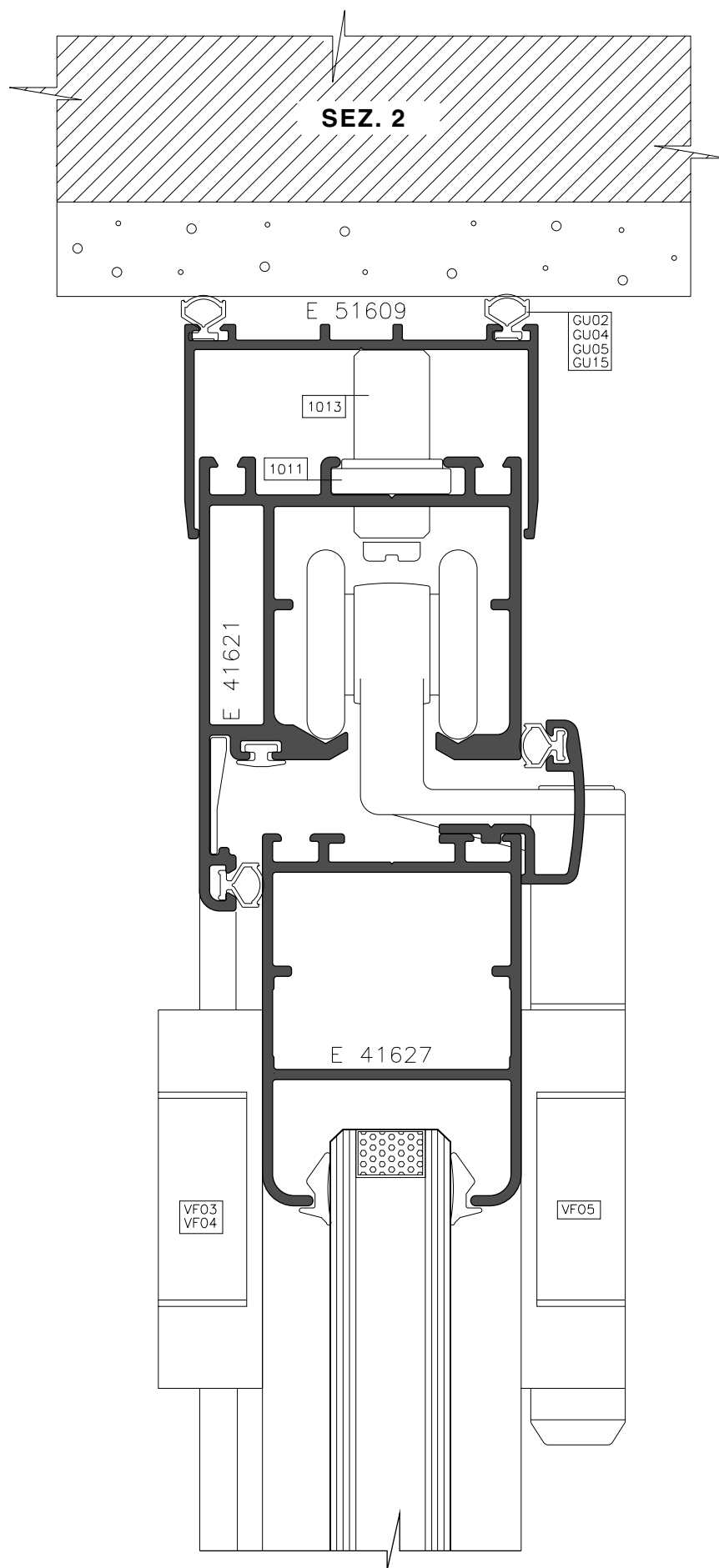

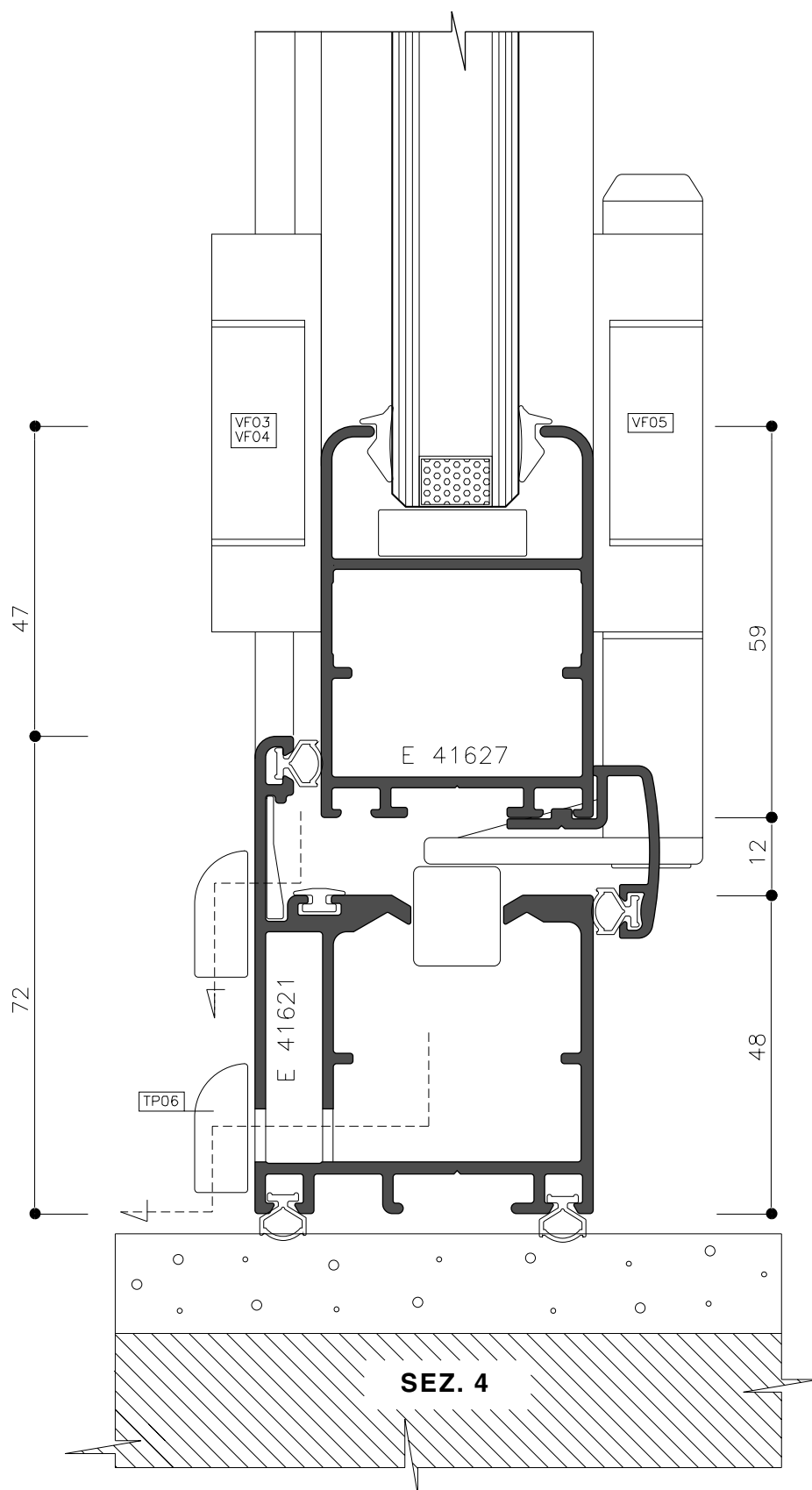
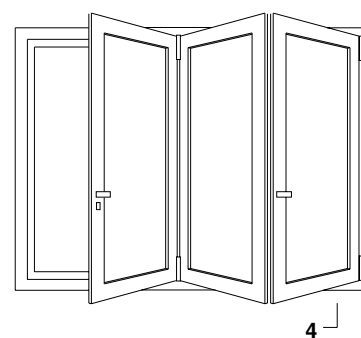

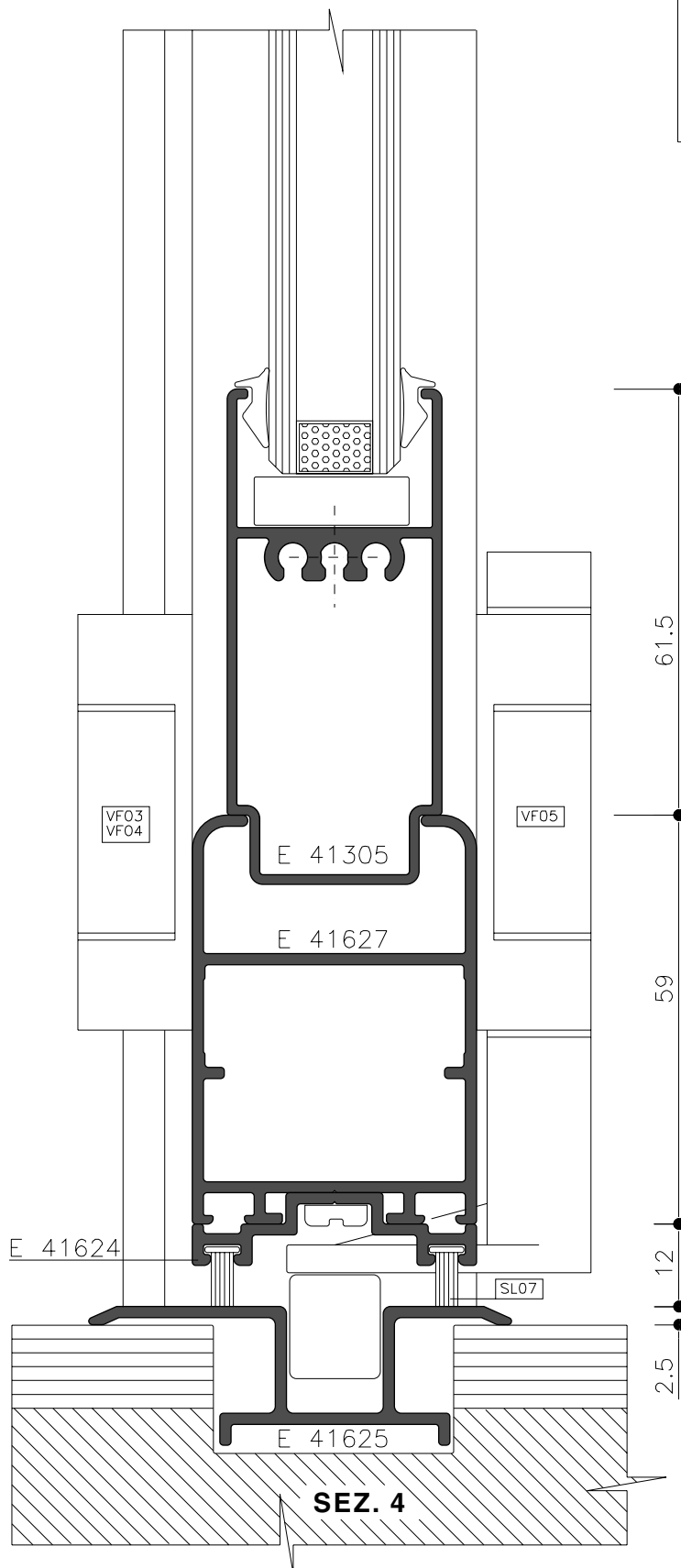
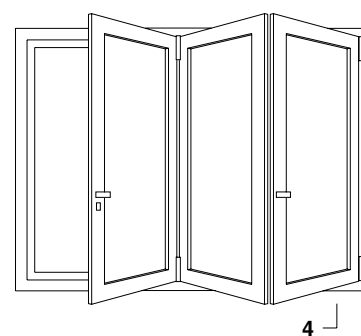

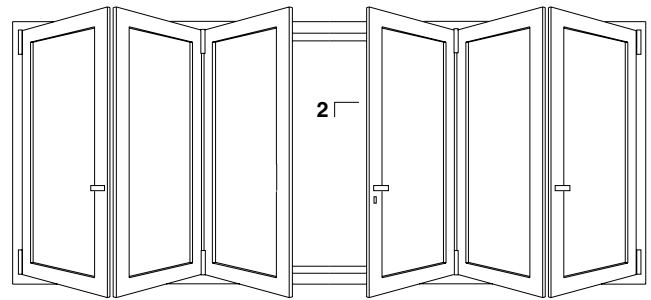

SEZ. 2

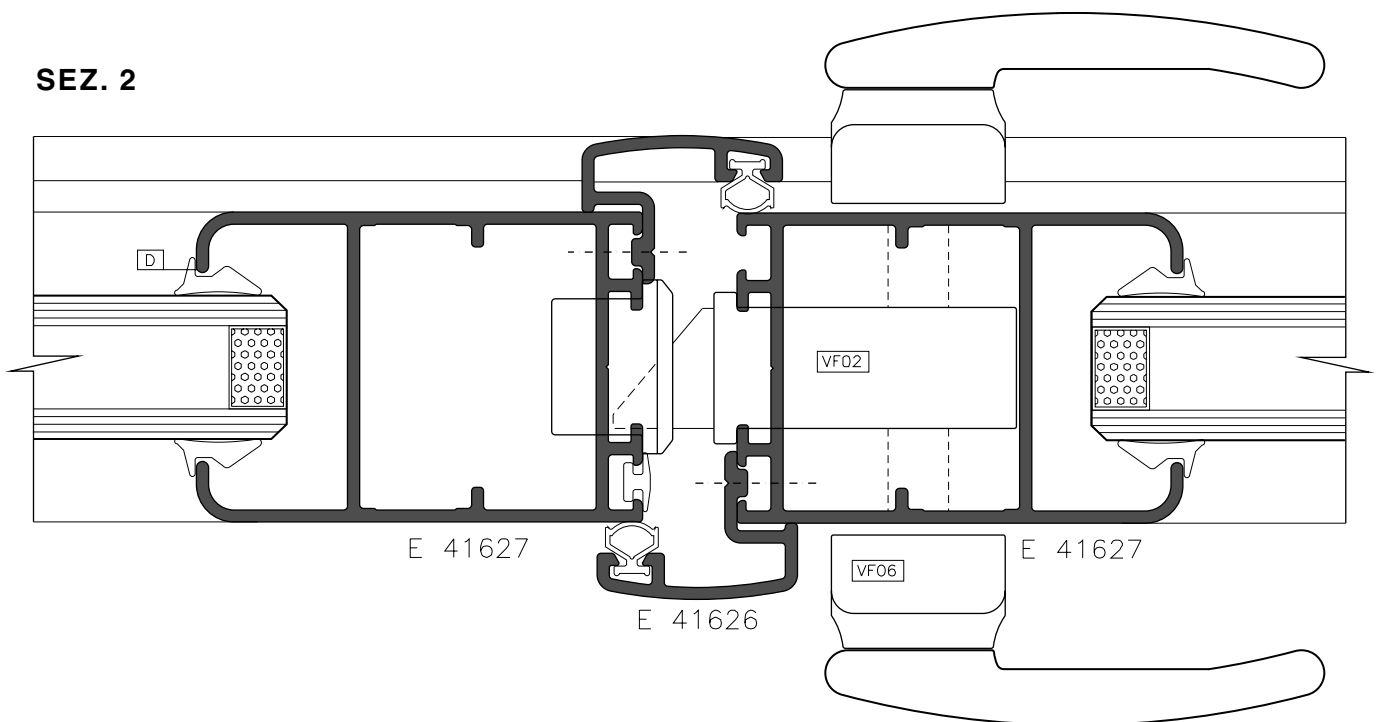



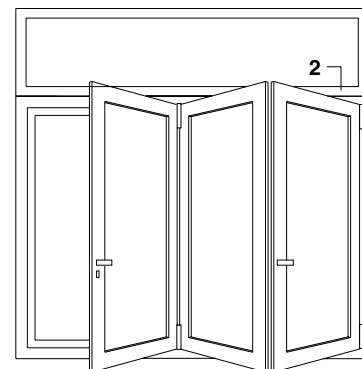
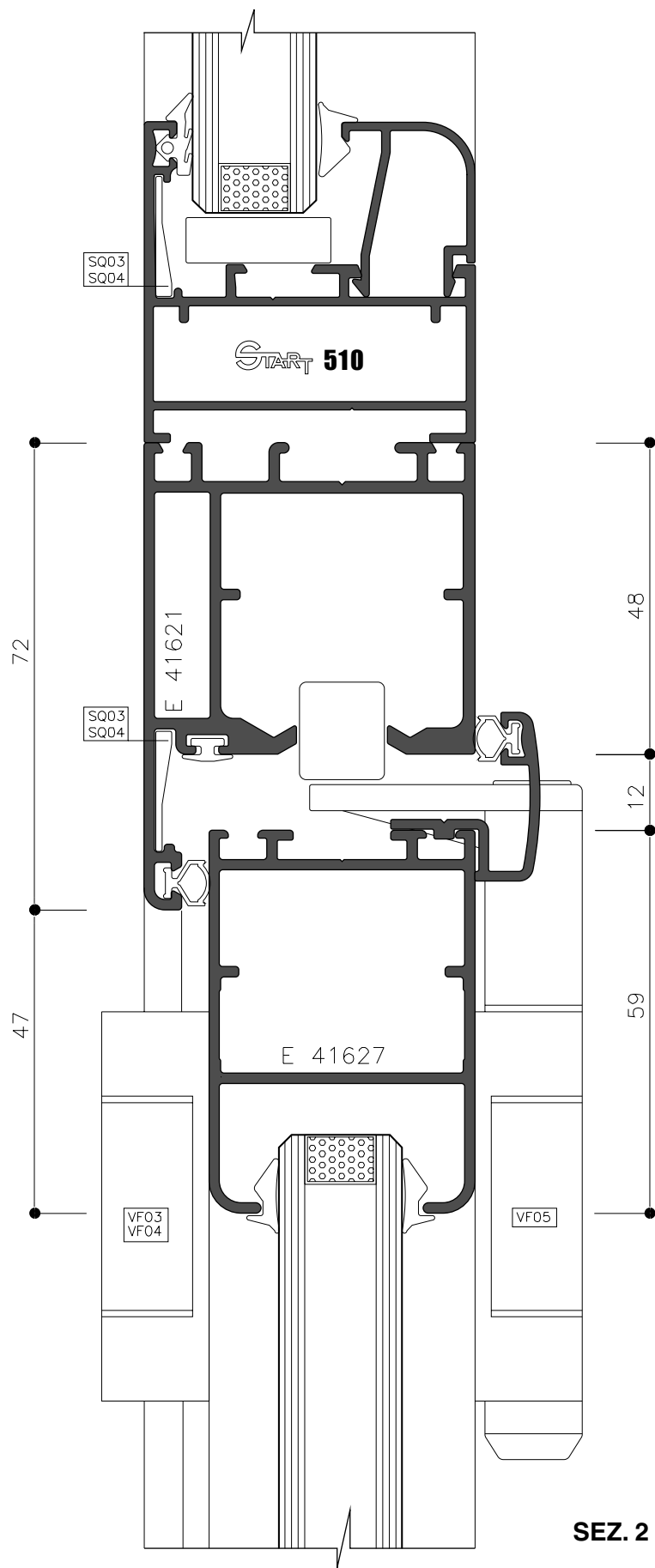

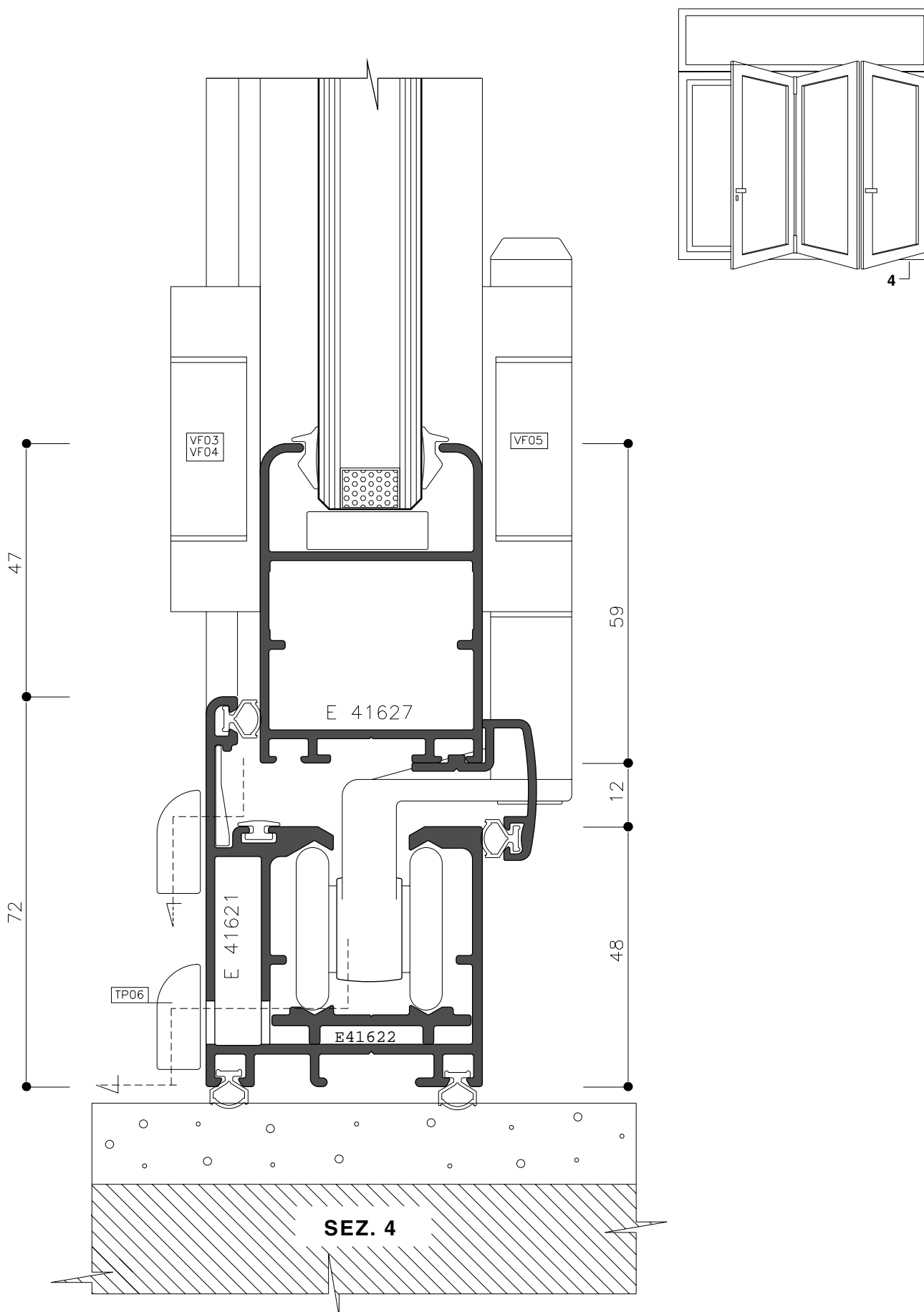

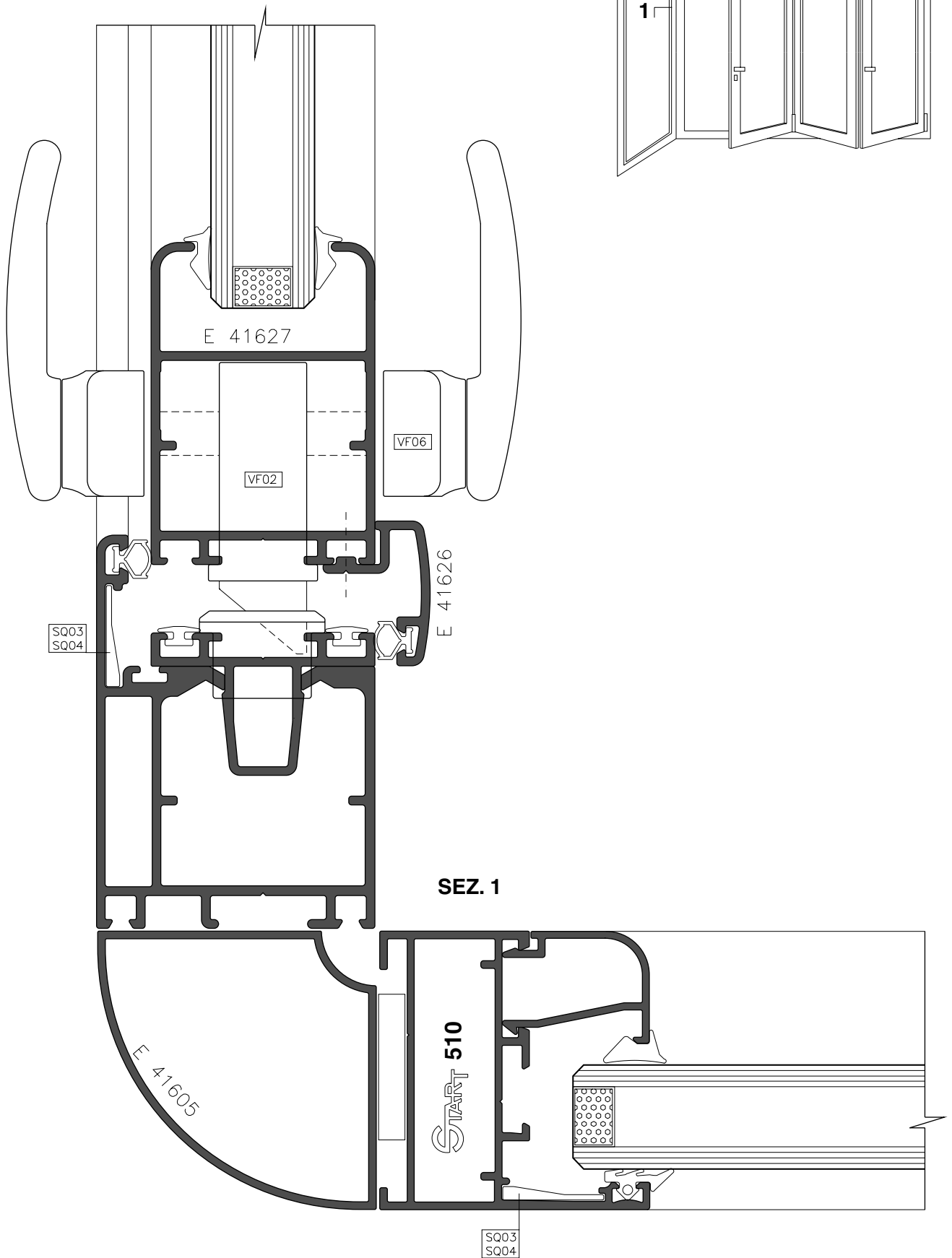

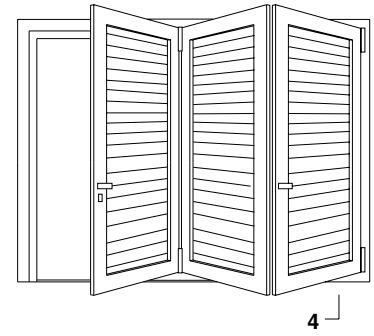
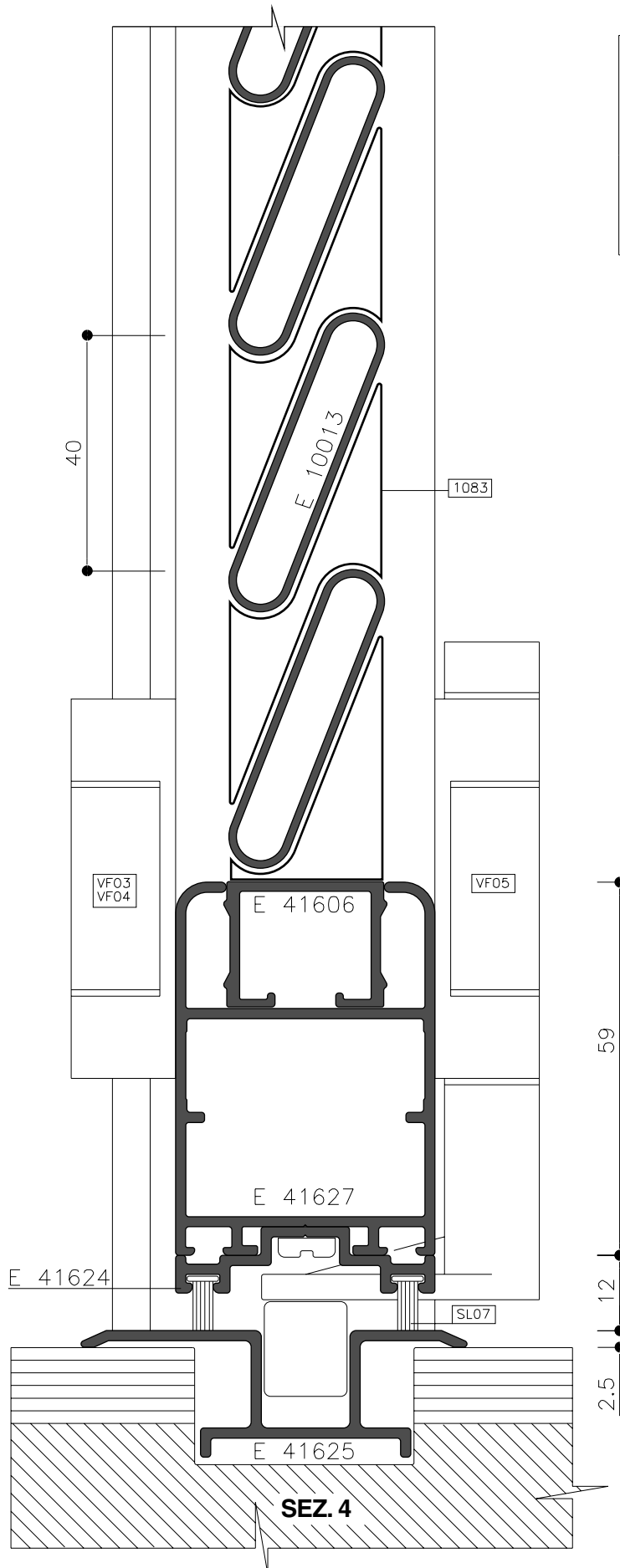

# schede di lavorazione



sistema  
**FLEX**

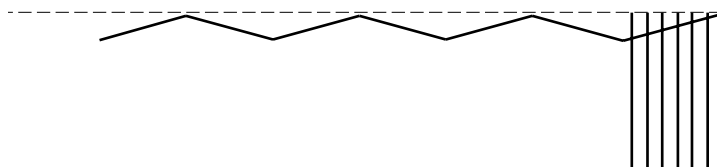
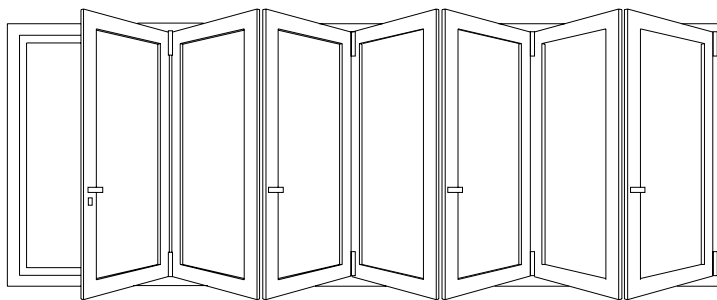
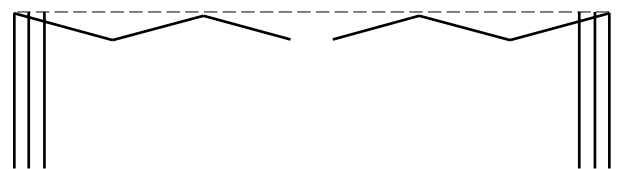
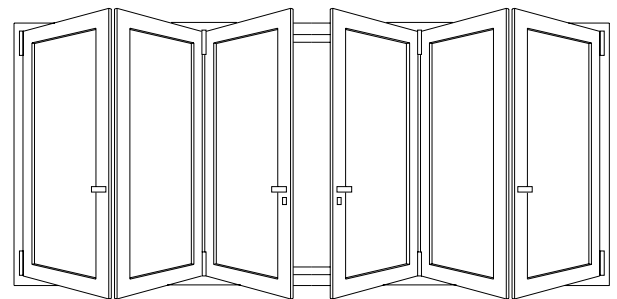
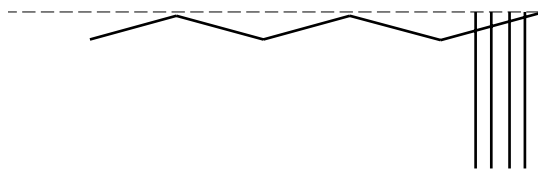
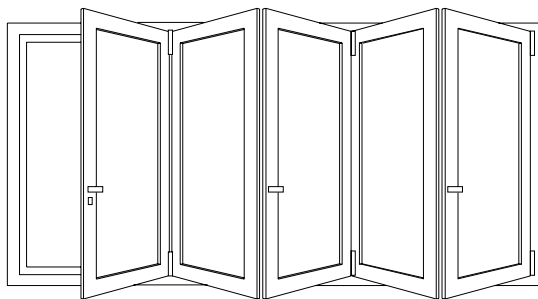
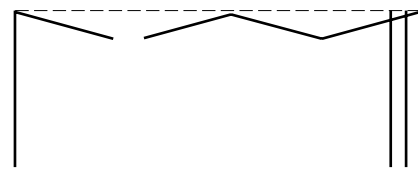
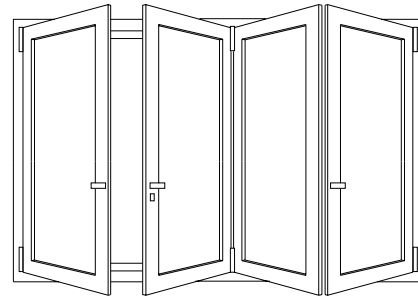
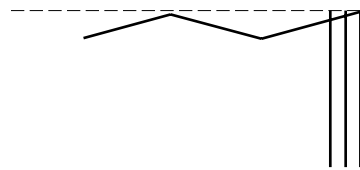
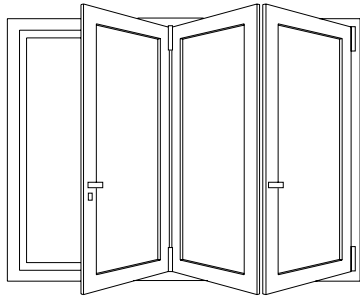

INGOMBRO VERANDA

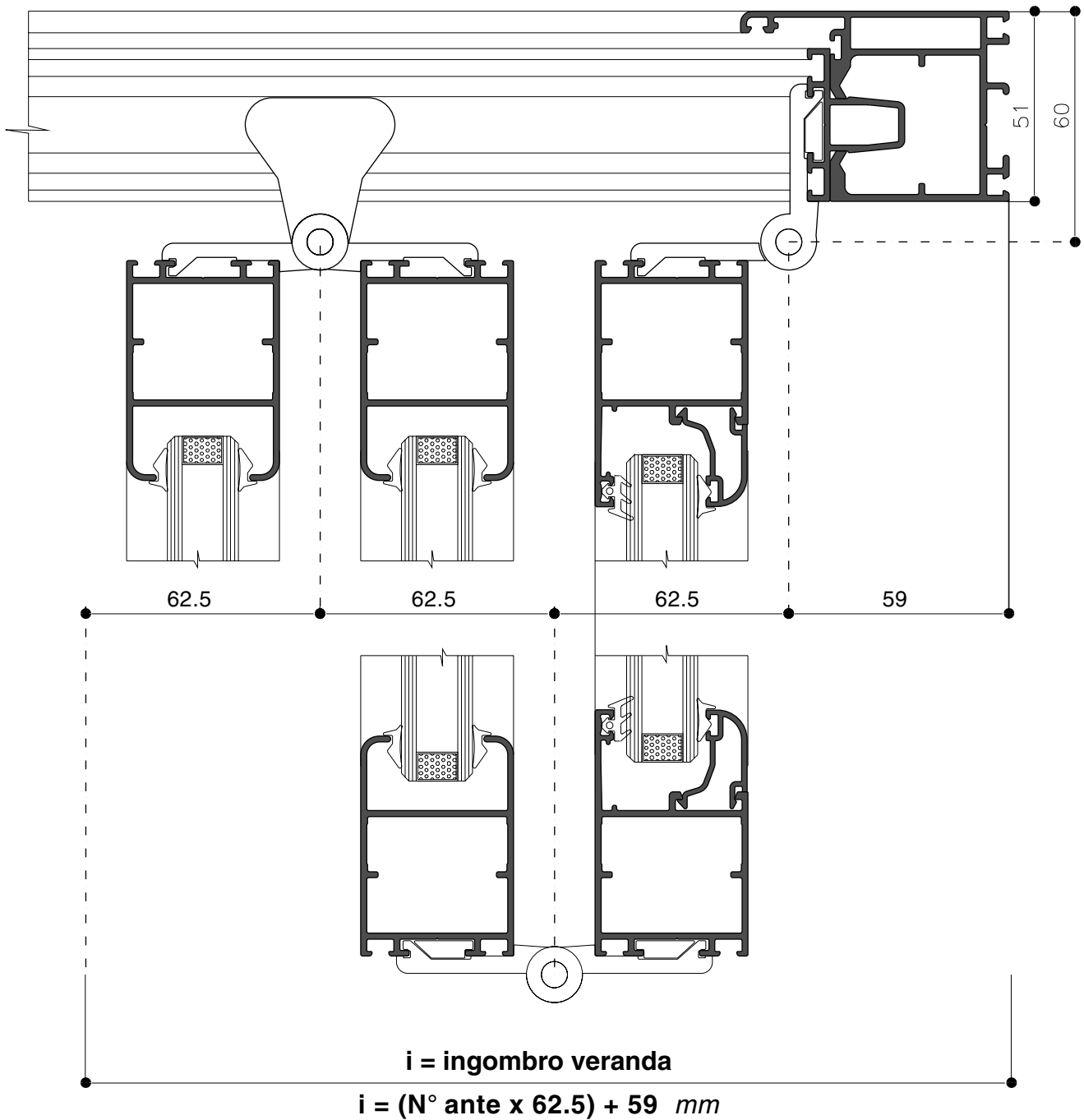

SOLUZIONE TELAIO 45°

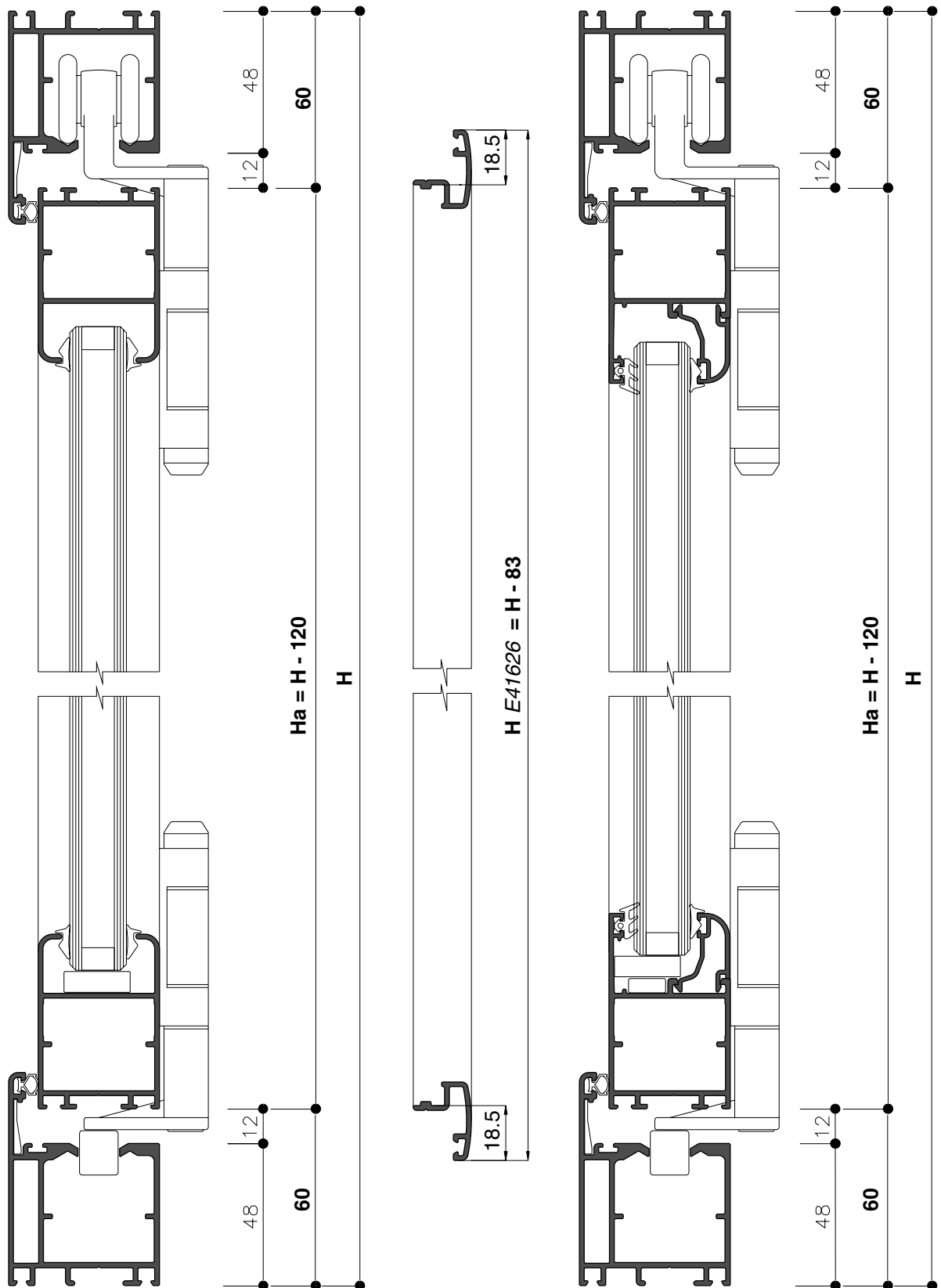

$H$  anta =  $H - 120$   
 $H E41626 = H - 83$



SOLUZIONE GUIDA INCASSATA

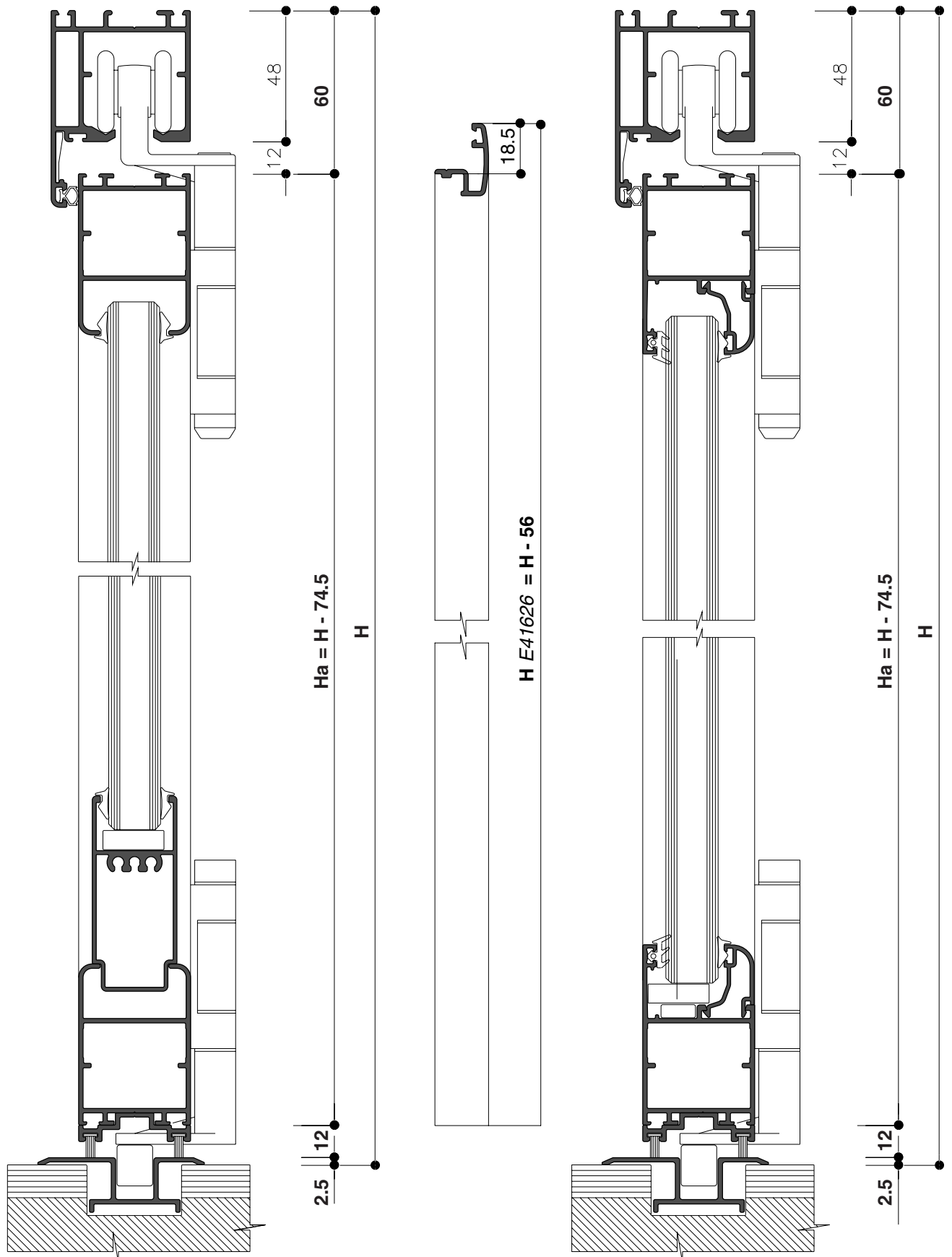

$H_{\text{anta}} = H - 74.5$   
 $H E41626 = H - 56$

### TELAIO A 45

ANTA BATTENTE

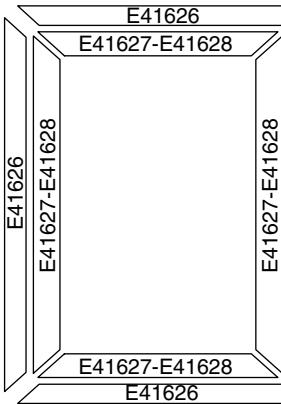

ANTA INTERMEDIA

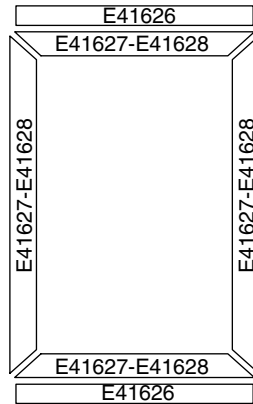

### GUIDA INCASSATA

ANTA BATTENTE

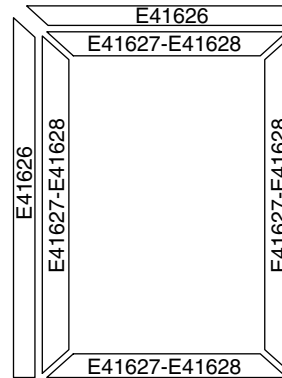

ANTA INTERMEDIA

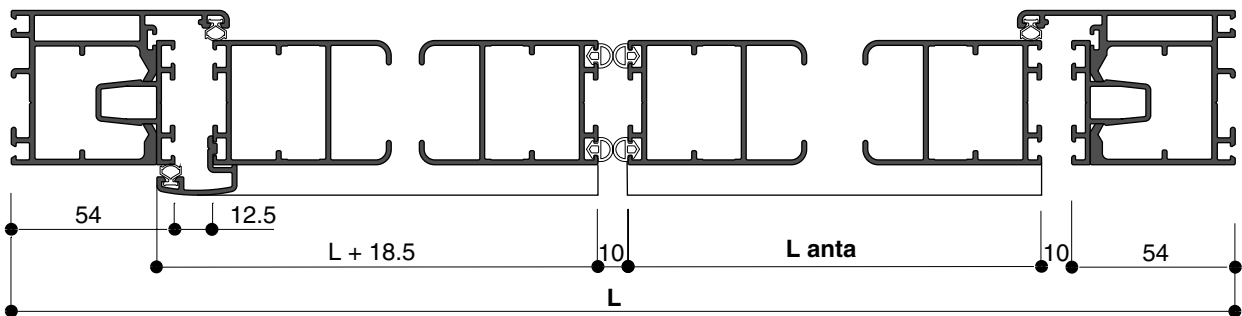
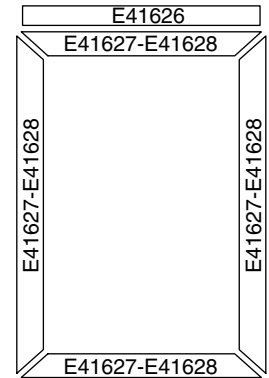

### LISTA DI TAGLIO PROFILI PER ANTE

$$L \text{ anta} = \frac{L - 120.5 - (10 \times N^{\circ} \text{ ante})}{N^{\circ} \text{ ante}}$$

n°2 pezzi x N° ante

#### SOLUZIONE TELAIIO A 45°

$$H \text{ anta} = H - 120$$

n°2 pezzi x N° ante

#### SOLUZIONE GUIDA INCASSATA

$$H \text{ anta} = H - 74.5$$

n°2 pezzi x N° ante

### LISTA DI TAGLIO PROFILO E41626

ANTA BATTENTE:  $L (E41626) = L_a (\text{anta}) + 18.5$

n°2 pezzi

ANTE INTERMEDIE:  $L (E41626) = L_a (\text{anta})$

n°2 pezzi x N -1

#### SOLUZIONE TELAIIO A 45°

ANTA BATTENTE:

$$H (E41626) = H - 83$$

n°1 pezzo

#### SOLUZIONE GUIDA INCASSATA

ANTA BATTENTE:

$$H (E41626) = H - 56$$

n°1 pezzo

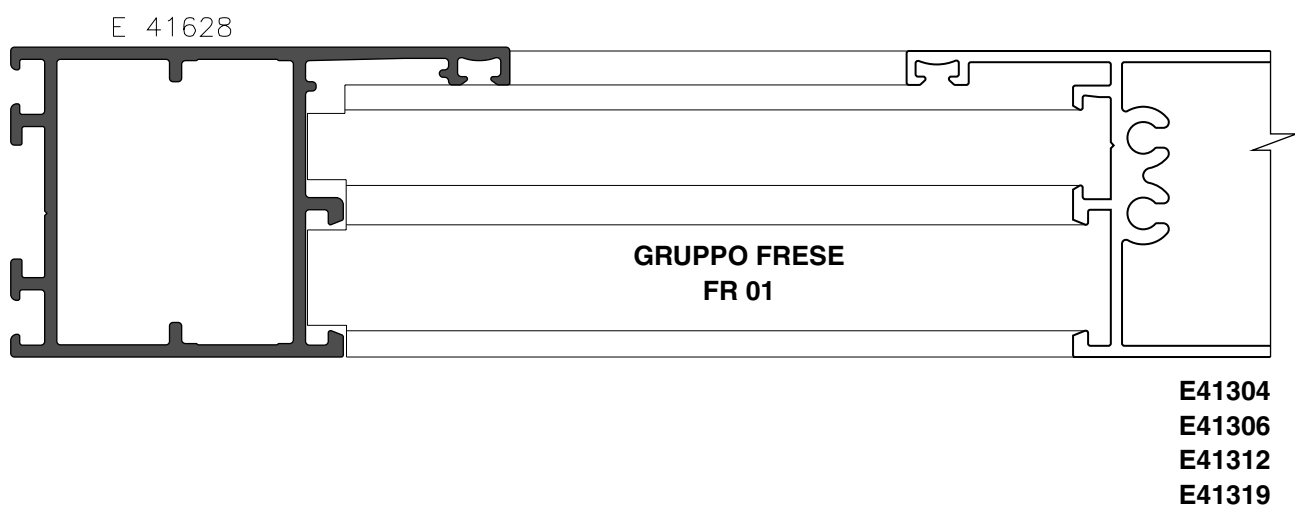
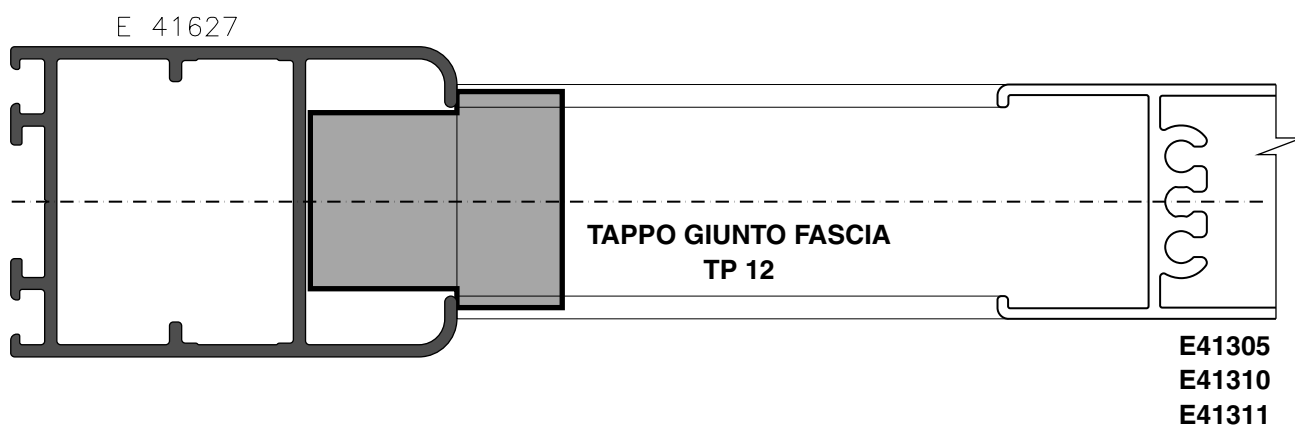
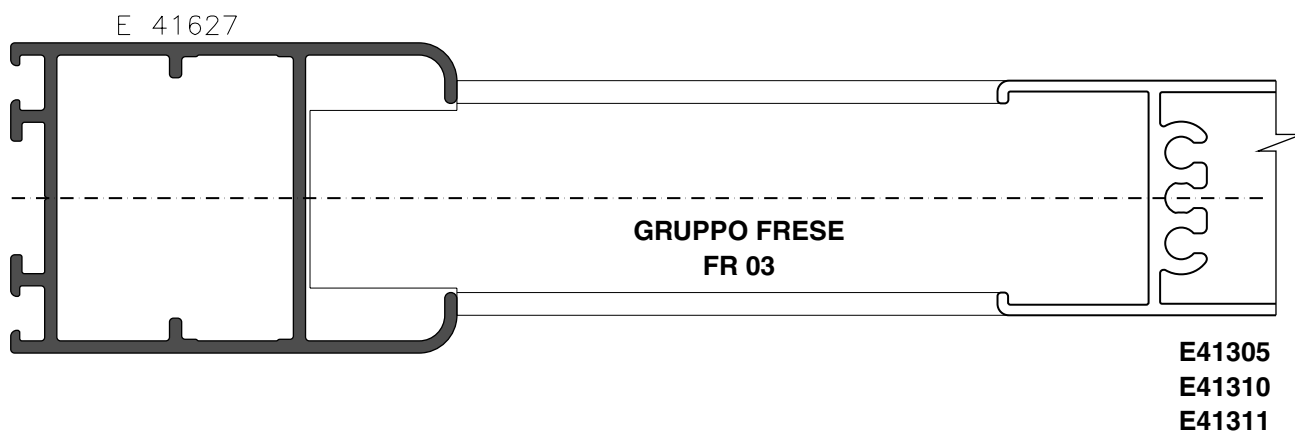

LAVORAZIONE art. SQ28

E 41628

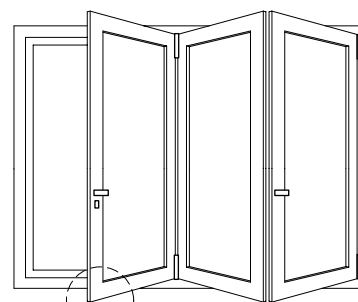
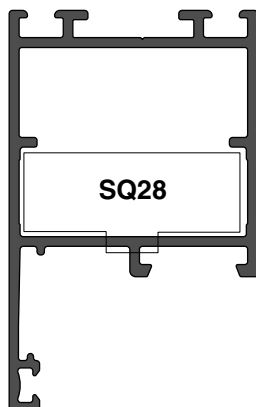

PART.B

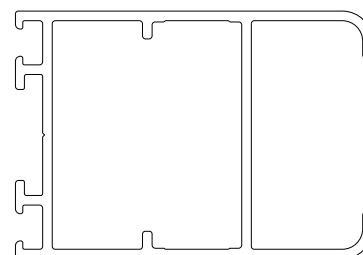

E 41627

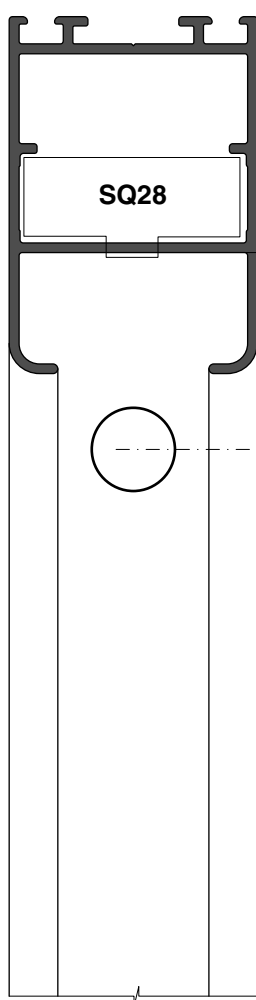

28

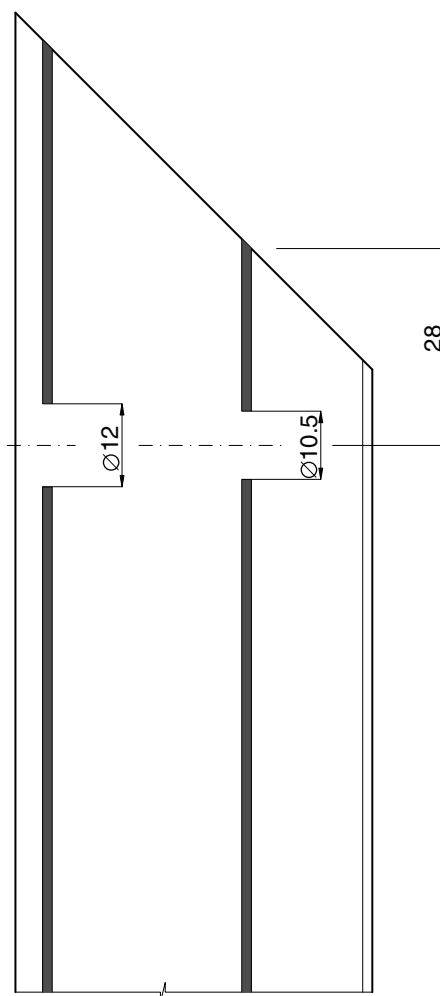

28

Ø12

Ø10.5

PART. B

UTENSILI PER LAVORAZIONE PANTOGRAFO  
TRAPANO

LAVORAZIONE art. VF 02

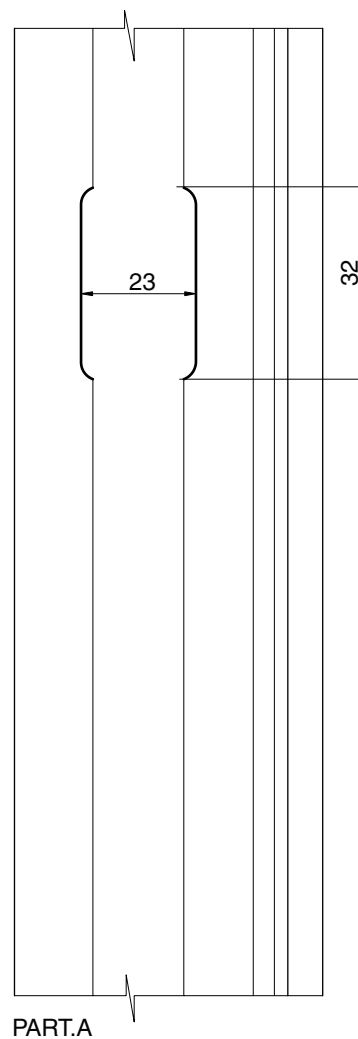
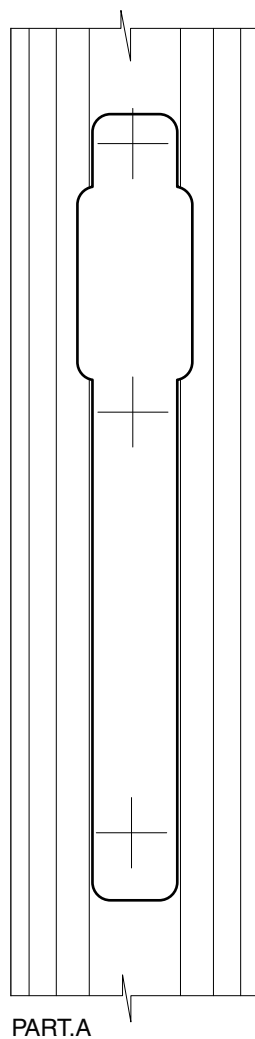
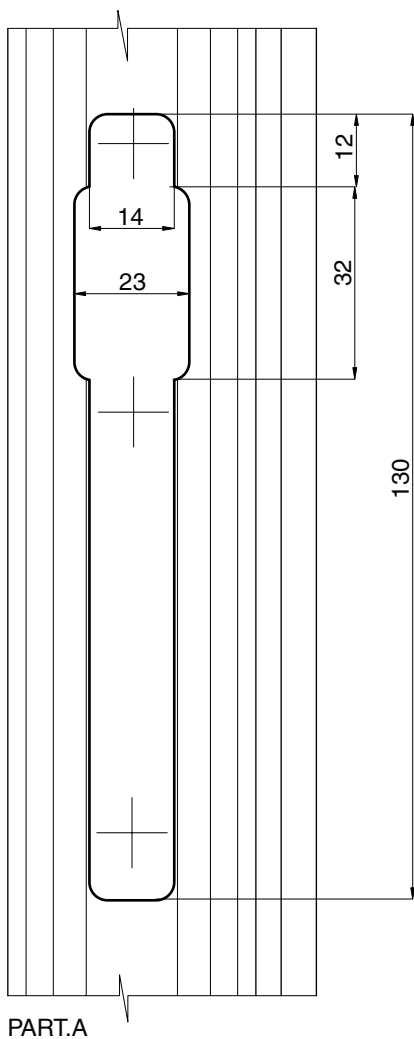
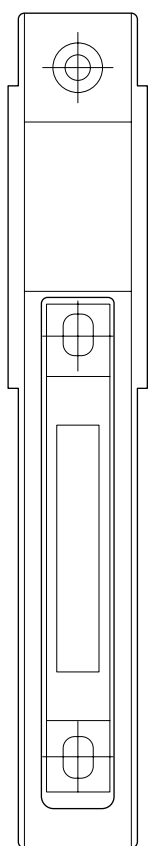
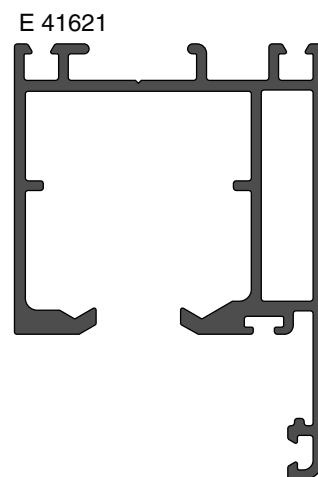
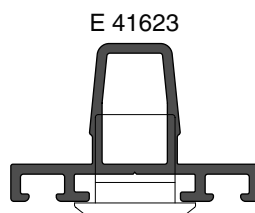
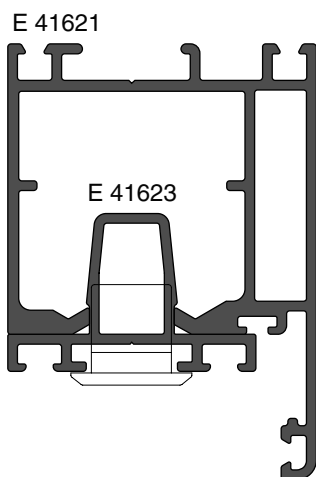
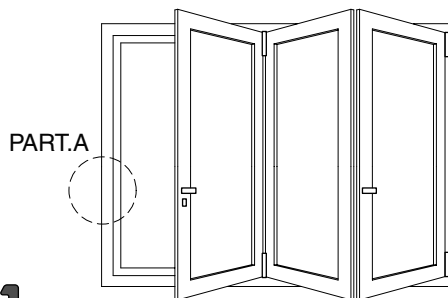

UTENSILI PER LAVORAZIONE PANTOGRAFO

LAVORAZIONE art. SQ01-SQ02

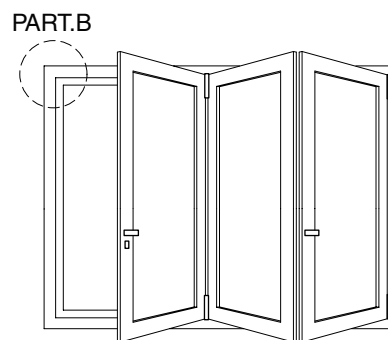

E 41621

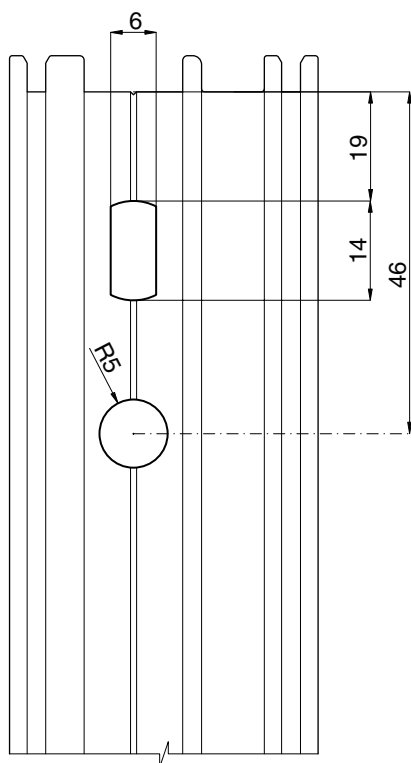
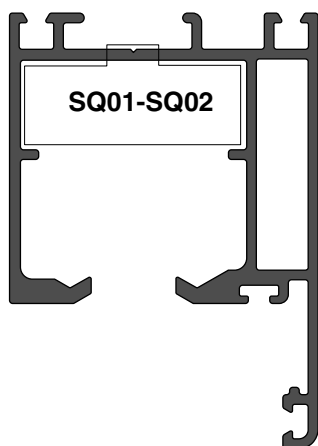

PART.B

UTENSILI PER LAVORAZIONE    PANTOGRAFO  
PUNZONATRICE PU01-PU02

LAVORAZIONE art. TP06

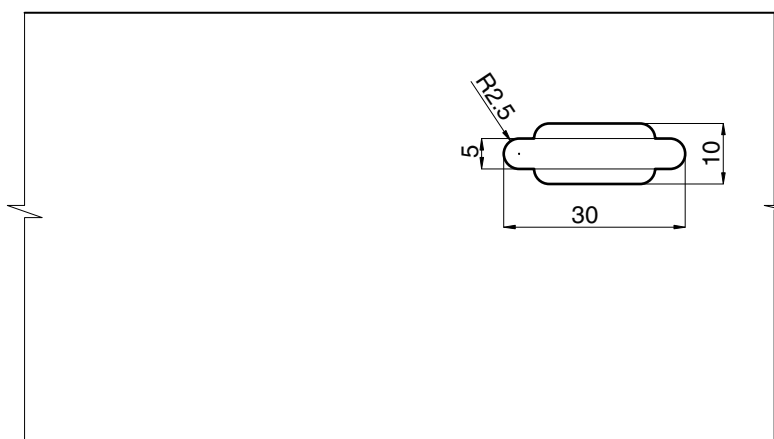
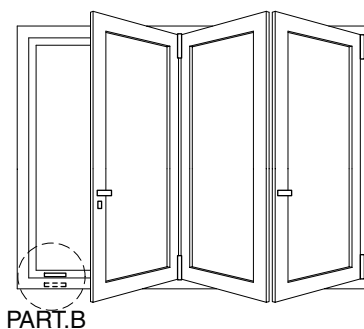

PART.B

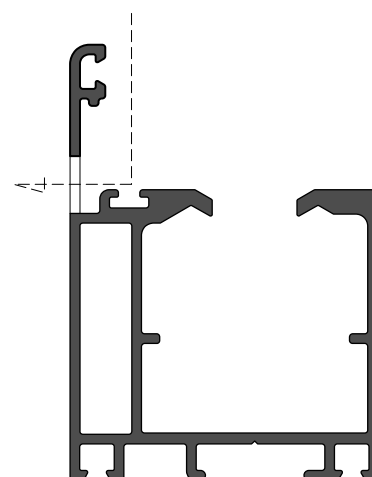

E 41621

UTENSILI PER LAVORAZIONE

PANTOGRAFO  
PRESSA PU01-PU02

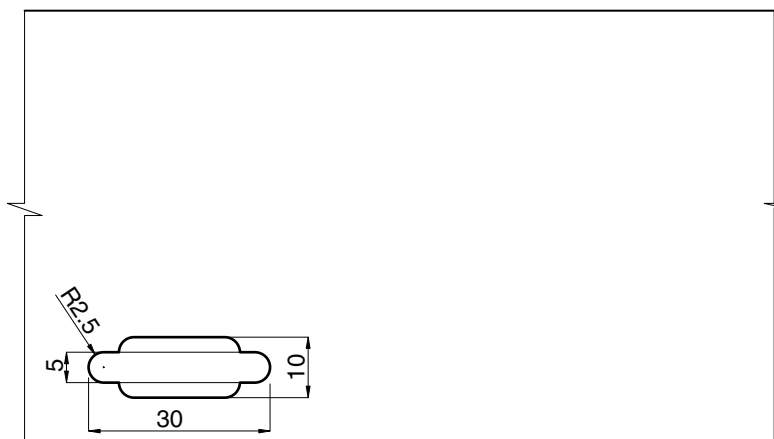

PART.B

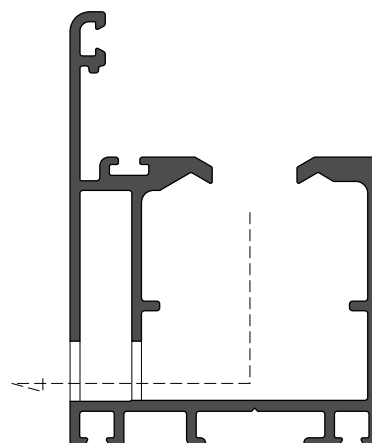

E 41621

UTENSILI PER LAVORAZIONE

PANTOGRAFO

LAVORAZIONE art. VF01

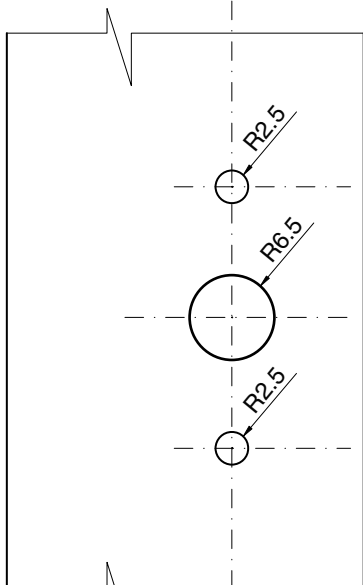
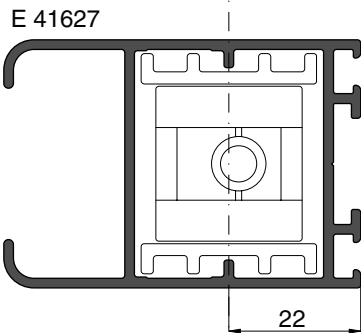
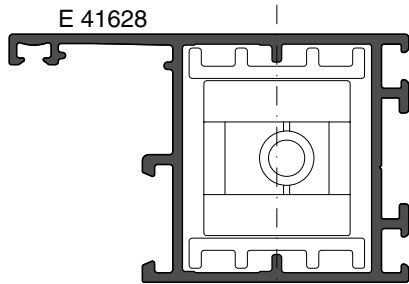
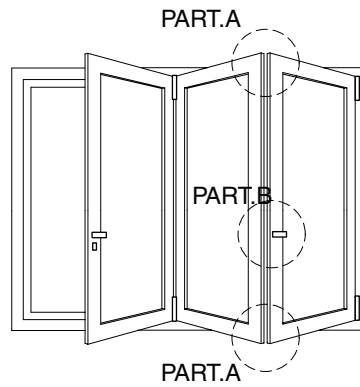

PART.B

LAV. TRAPANO

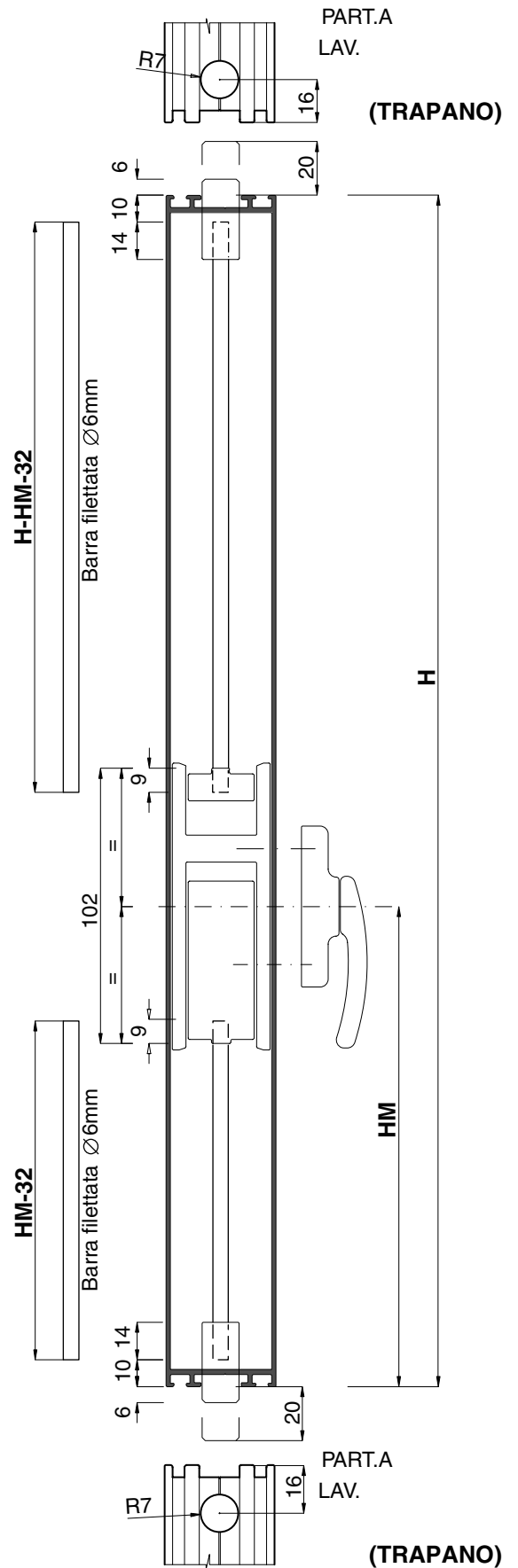



LAVORAZIONE art. VF02

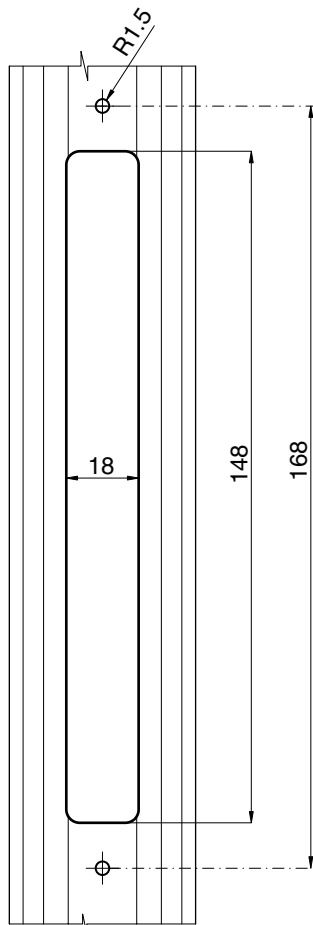
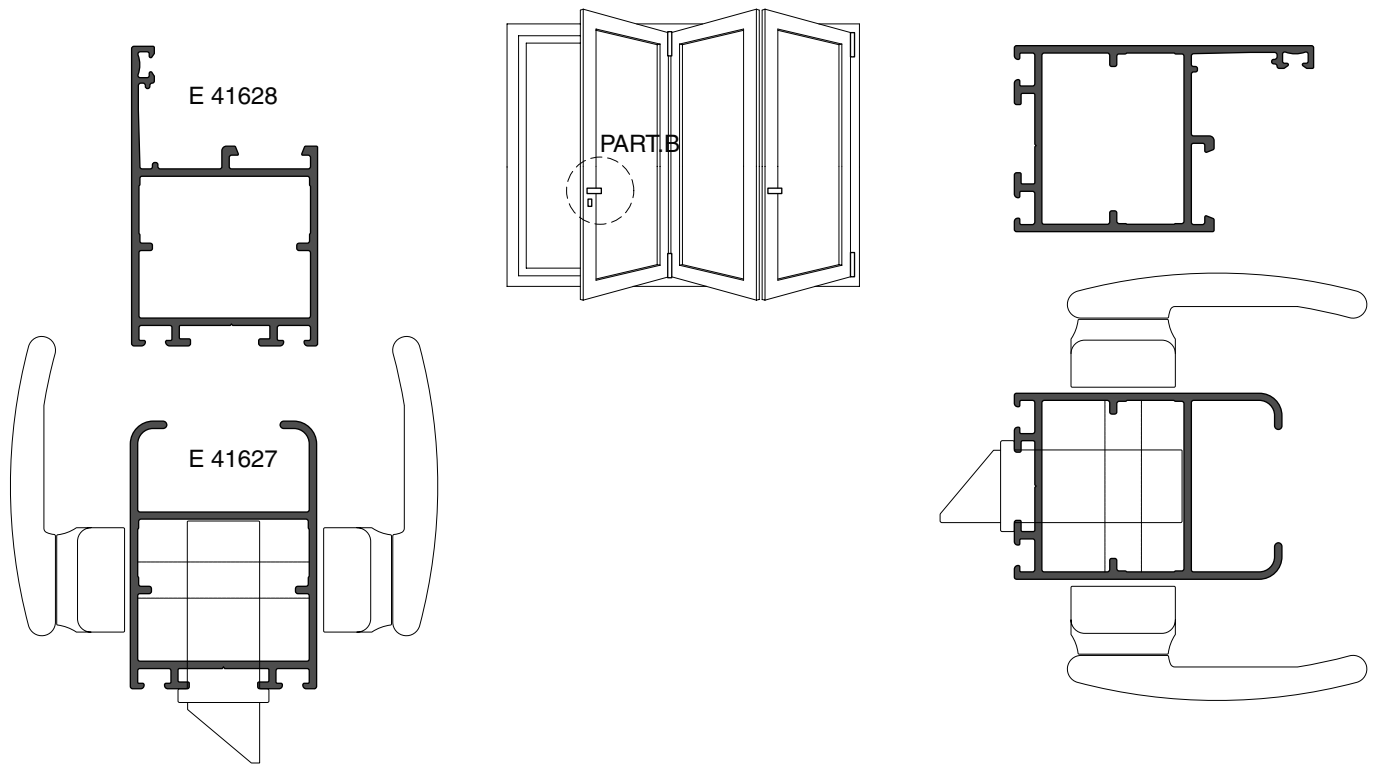

PART.B

UTENSILI PER LAVORAZIONE PANTOGRAFO  
TRAPANO

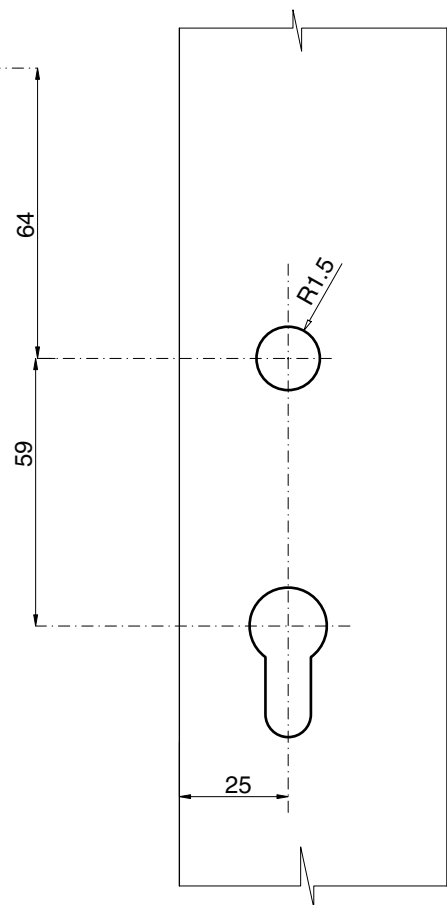

PART.B

PANTOGRAFO  
TRAPANO

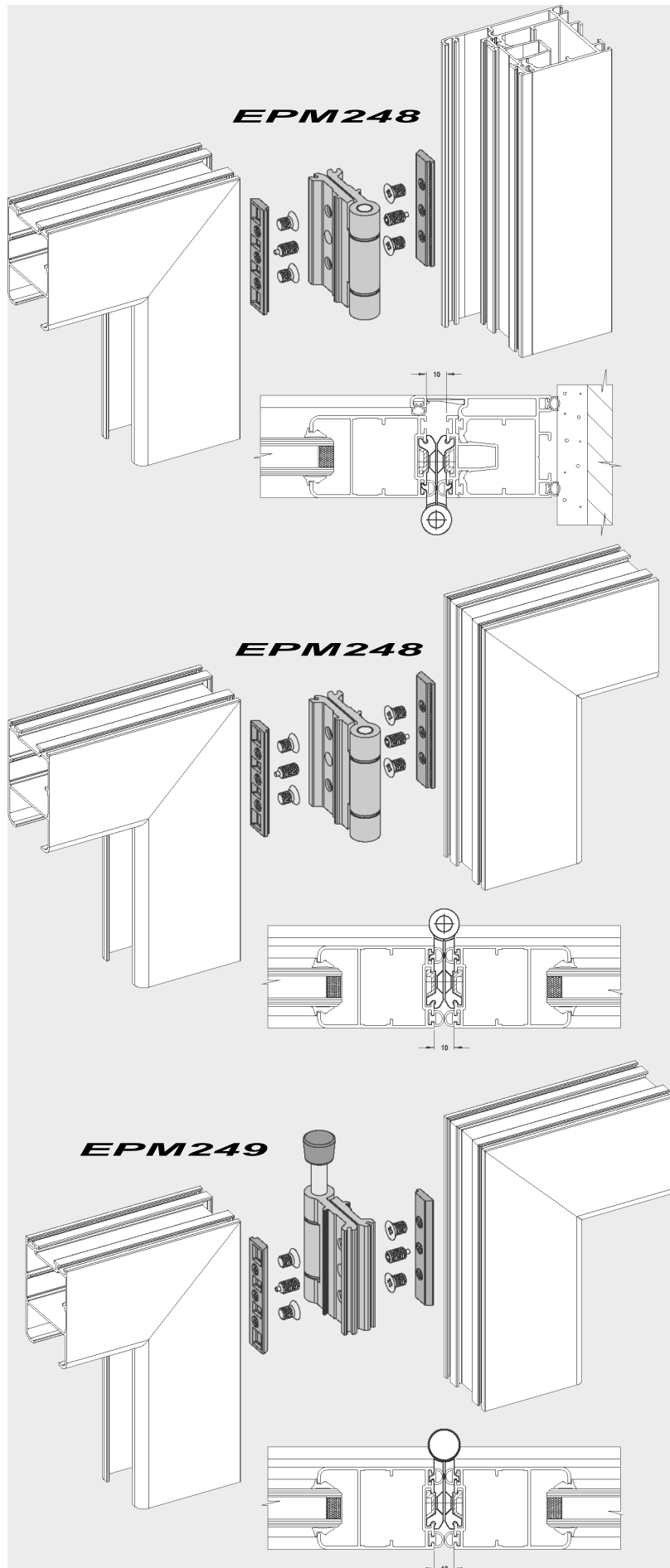

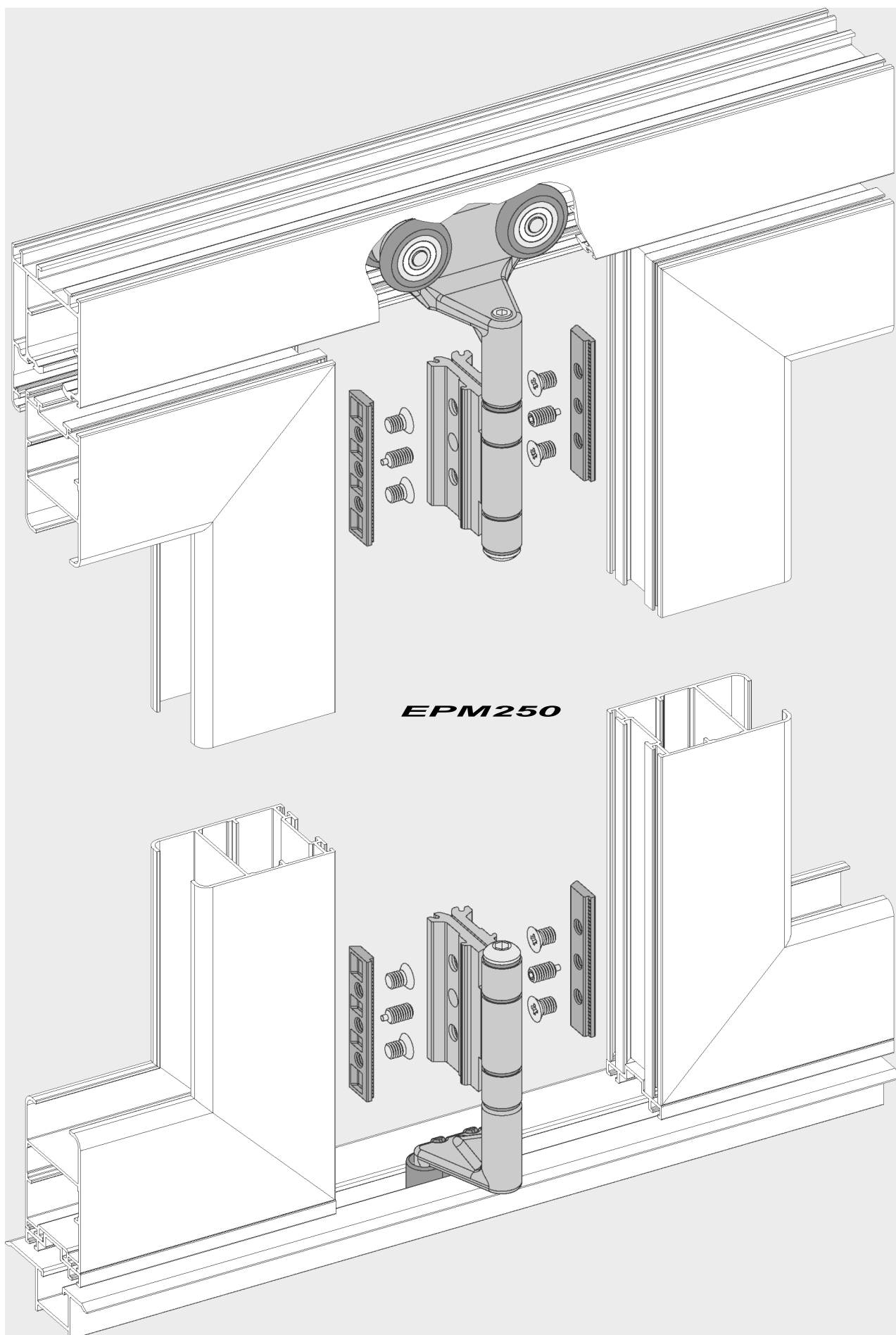

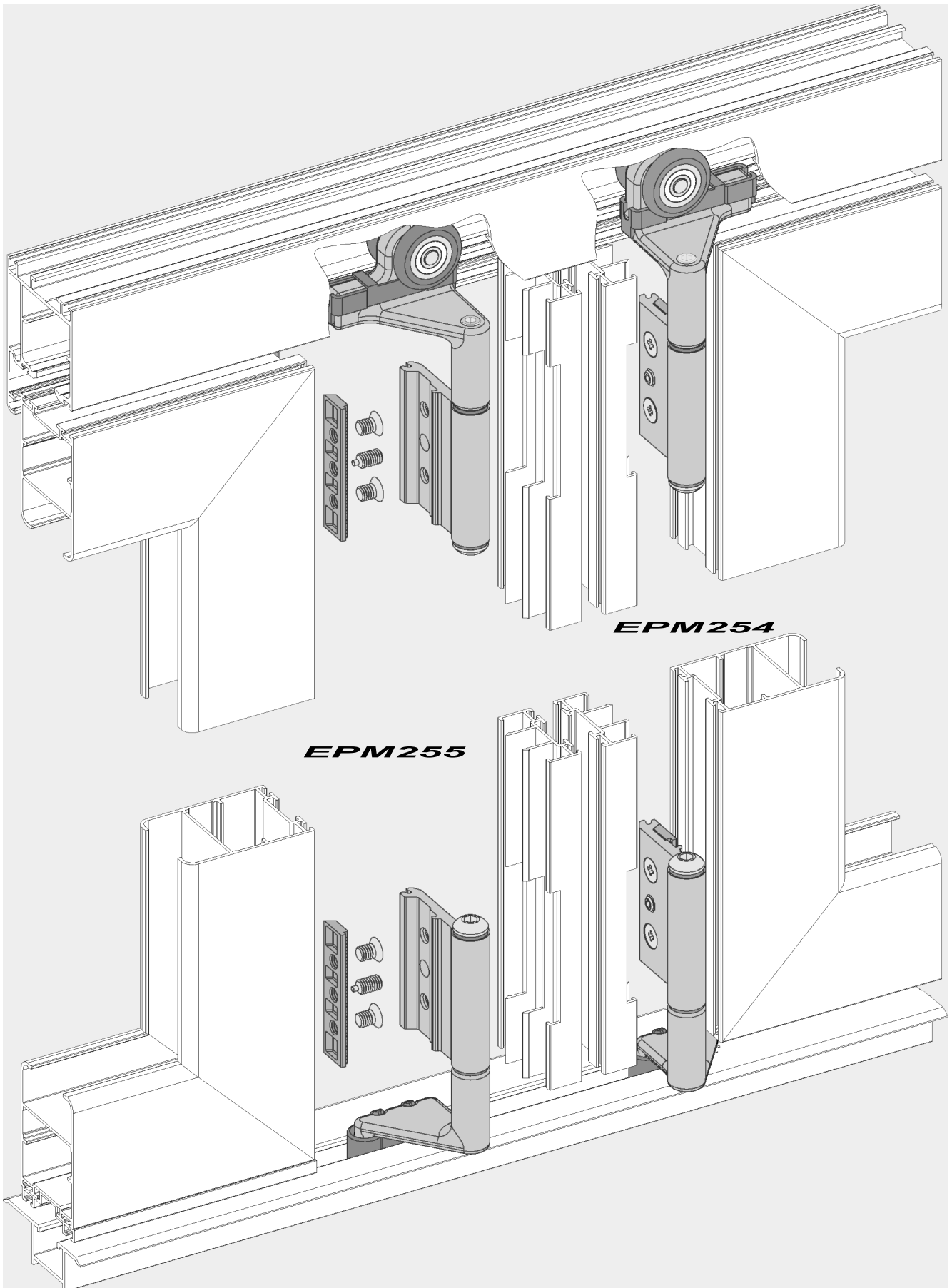

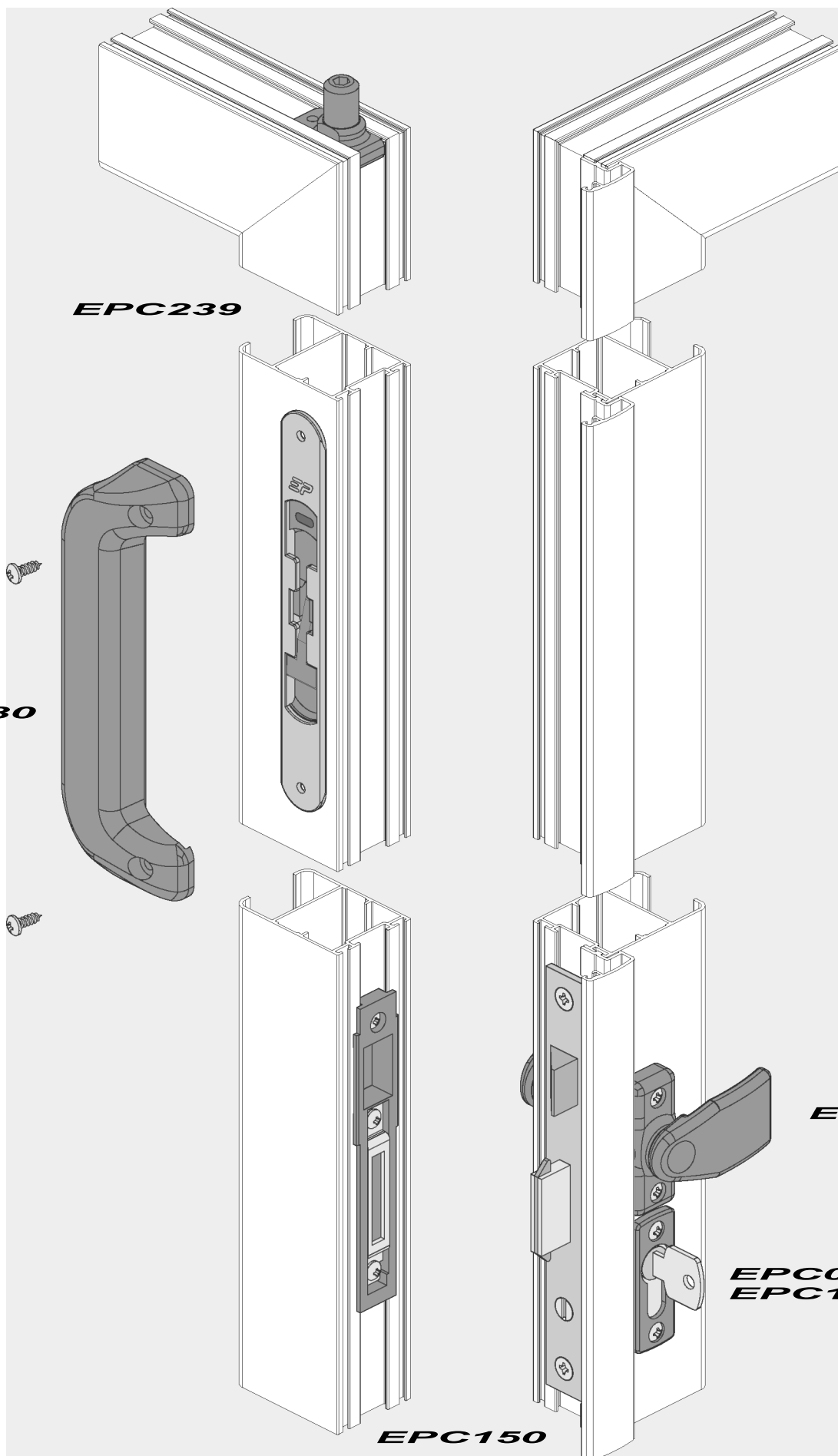

**EPC236**

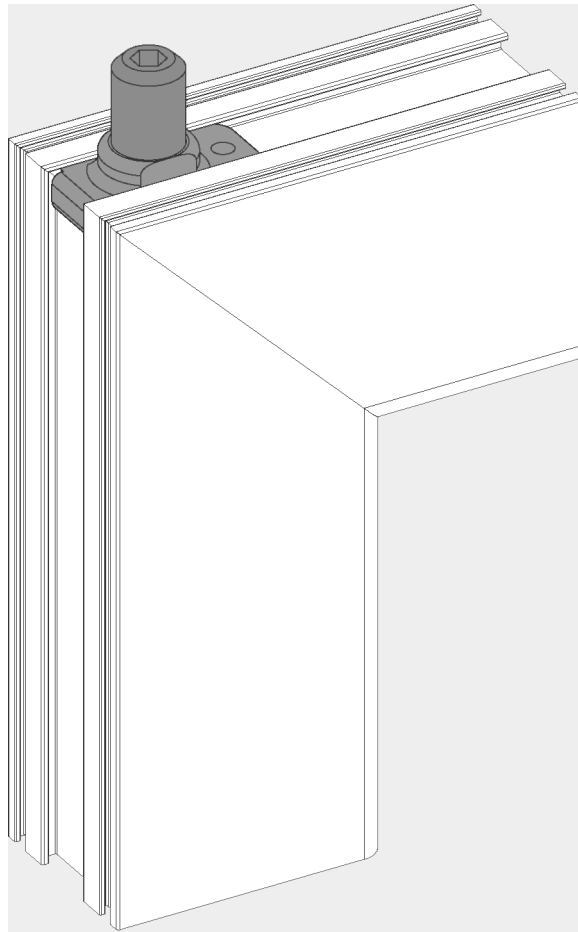

**EPC236**

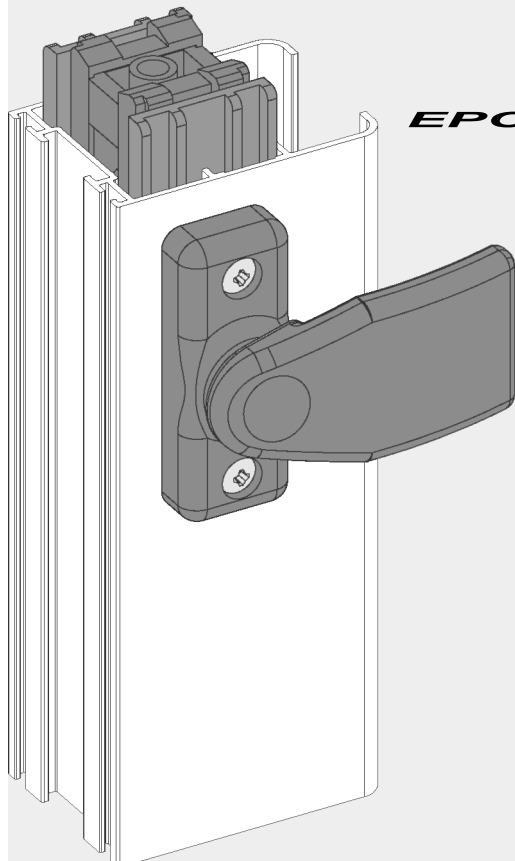

**EPC128**

